

Original language instruction

Warnings 3

Recommendations for woven applications 4



Ballon Control and Tensioners

S-Flex Compensating tensioner and ballon control A
 E-Flex Compensating tensioner and ballon control B
 Lamella Brake C



Tensioners

TEC Weaving Machine controlled (CAN) active tensioner D
 CAT Coaxial Output Tensioner E
 Unibrake F
 Compensator G
 Leaf tensioner H
 Rotating disc tensioner I
 Twin Around Brake J



Ballon Control

Brush ring K



Self-adjusting Devices

Posiflex L
 ATC-W Active Tension Control for Weaving Applications M
 TED Tension Display N



Yarn Break Sensors

Piezo Sensor O



Knot Sensors

Knot Sensor P



Bobbin Switch Sensors

Bobbin Switch Sensor Q



Lubricators

Mechanical Weft Lubricator R
 Powered Weft Lubricator S

This section contains important safety information. Read the manual carefully before installing, using or maintaining the weft feeder.



WARNING

Indicates a possible dangerous situation which could result in serious injury or damage to the unit.



CAUTION

Indicates a possible dangerous situation which could result in minor/moderate injury or damage to the unit.

NOTE

Used in order to draw attention to important information, which facilitates operation or handling.

IRO AB reserve the right to change the contents of the user's guide and technical specifications without prior notification.

**WARNING!**

- The power supply must be switched off at the mains before any work is carried out on the feeder, the transformer/interface or any other electrical components. The feeder and the transformer cabinet and cable covers must be fully assembled before the power supply is connected.
- The weft feeder ON/OFF-switch **DO NOT** cut off the main power supply. Turn off the main switch before any work is carried out on the electrical circuit.
- The feeder and transformer contain electrical components that retain an electric current up to three minutes after disconnection. **DO NOT** open or disconnect feeder or interface, including cables, within this time.
- All work on electrical components must be carried out by a qualified electrician.
- This product is not intended for use in potentially explosive atmospheres or in zones classified according to the European directive 94/9/ec. Please contact IRO AB if products for use in a potentially explosive atmosphere are required.
- Always turn off the main switch or isolate the power supply and disconnect the air supply before connecting or disconnecting the feeder, the control board or any of the circuit boards
- Routine checks for damaged or worn parts must be made before operating this equipment. Any part that is worn or damaged should be properly repaired or replaced by authorized personnel. To avoid risk of injury **DO NOT** operate this equipment if any component does not appear to be functioning correctly.
- Take necessary precautions to avoid injuries when interacting with the product. Use suitable respiratory and eye protection.
- Improper handling at repair, fault finding or similar may damage the feeder/interface mechanical/electrical components including cables and connectors. **DO NOT** perform measurements on feeder electrical components and parts. Please contact your local IRO AB service station for further information.

**CAUTION!**

- Caution must be taken in the close vicinity of the feeder as it contains moving parts that can cause injuries and, in normal operation, starts without prior warning.
- To comply with C.E. Regulations only replacement parts approved by IRO AB may be used.
- The feeder is an industrial product and therefore not approved to use household environments /in residential areas.

NOTE

- To ensure the selection of the most suitable feeder and associated accessories, it is recommended making weaving tests with the intended yarns.
- Please dispose of obsolete or unwanted equipment responsibly, taking into consideration any local regulations regarding the disposal and / or recycling of materials that are applicable.
- All products in this manual may not be available for your market.
- The performance of a tensioner can be affected by various factors connected to the specific yarns being used. In case of uncertainty it is recommended to carry out a weft insertion test.



Our way to the perfect fabric

Perfect fabric is the result of a combination of elements in the weaving process, with a key element being the correct set-up of the weft accumulators used on the weaving machine.

The core function of a weft accumulator, as a fundamental necessity in the weaving process, is the ability to minimize tension variations in the yarn insertion, from the bobbin to the weaving machine. This core function of the weft accumulator can be further enhanced by incorporating unique accessories.

- Output brakes that optimise yarn tension throughout the weft insertion process, ensuring the correct level required for both loom performance and fabric quality.
- Input brakes for ensured weft accumulator functionality, and to help equalize yarn tension variations between different bobbins.
- Self-adjusting devices that automatically supervise chosen settings.
- Weft detectors that can recognize yarn defects, for example knots, and prevent these defects from entering the fabric.
- Precise lubrication devices to increase the quality and performance of yarns that may benefit from the application of lubricants.
- A range of the most technologically advanced speciality devices for the most demanding of applications.
- Customized solutions for the most challenging yarns to weave.

In this manual we would like to share our expertise with recommendations for many different woven applications to help create perfect fabric.

Recommendations for different woven applications

Wool	5
Furnishing and upholstery	5
Shirting	6
Denim	6
Silk, filament and fancy fabrics	6
Curtains	7
Bed sheeting and towels.....	7
Tablecloths and household linen.....	8
Automotive and technical fabrics.....	8

WOOL

Quality and status are traditions we proudly share with wool weavers.

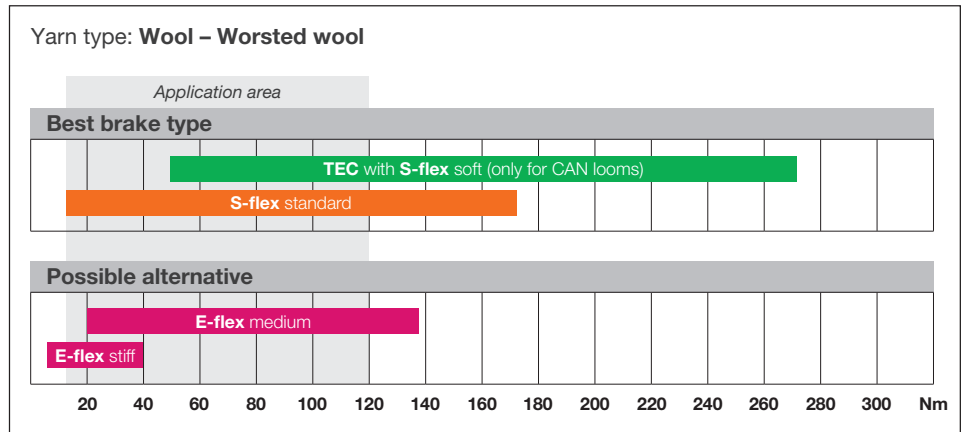

FURNISHING AND UPHOLSTERY

Unique fabrics produced for home furnishings using flexible weaving technology.

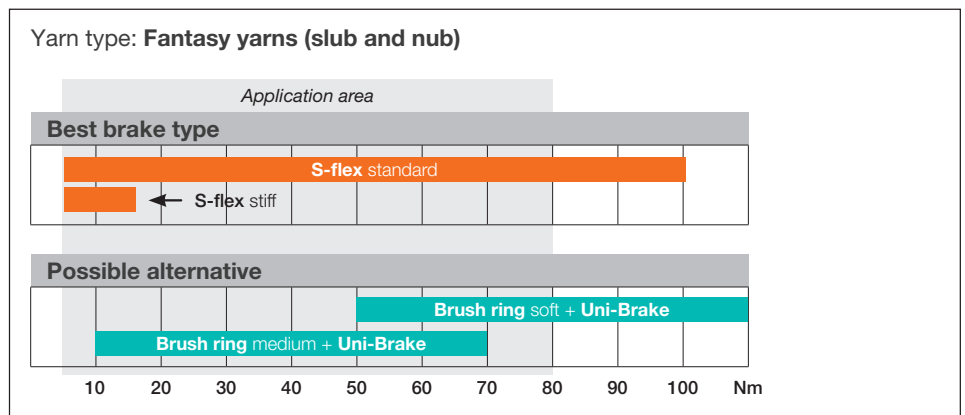
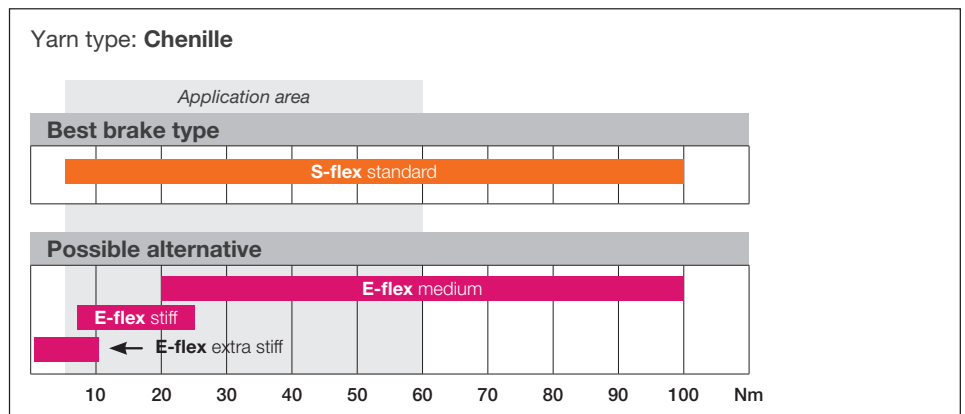

SHIRTING

A fresh, clean shirt everyday, chosen to show our style, attitude and individuality – the same criteria by which we challenge ourselves in the innovation of our products.

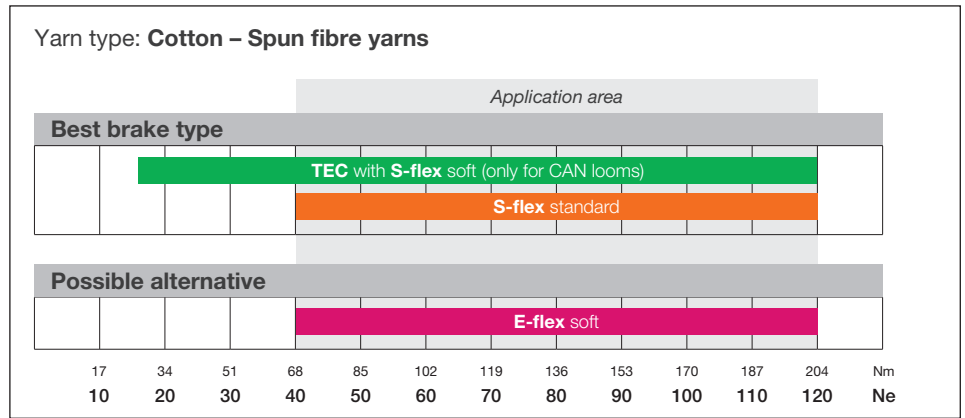

DENIM

Like denim and the denim weavers, our feeder systems are designed by building on the traditional with a view to the modern, to produce durable value for our costumers.

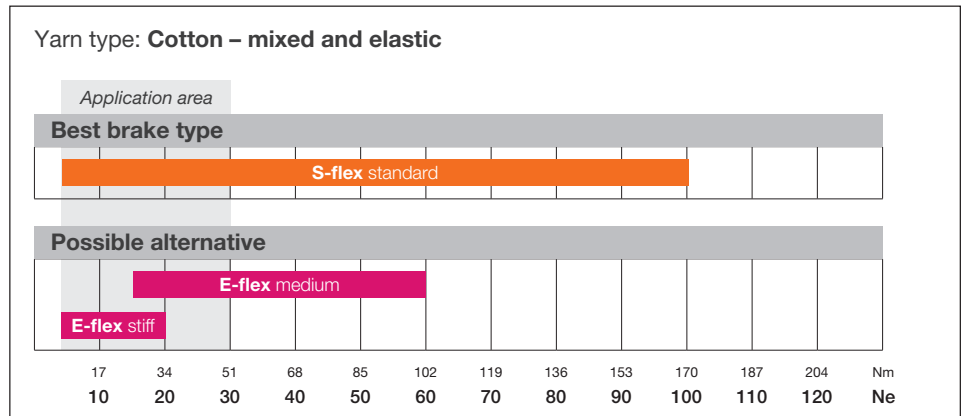

SILK, FILAMENT AND FANCY FABRICS

Detail, creativity and flare – characteristics we share with the designers of fancy fabrics and accessories.

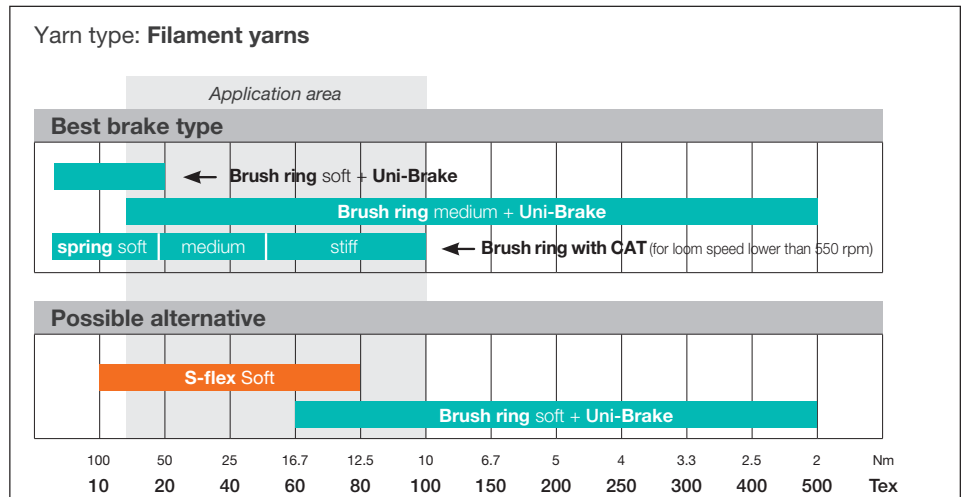
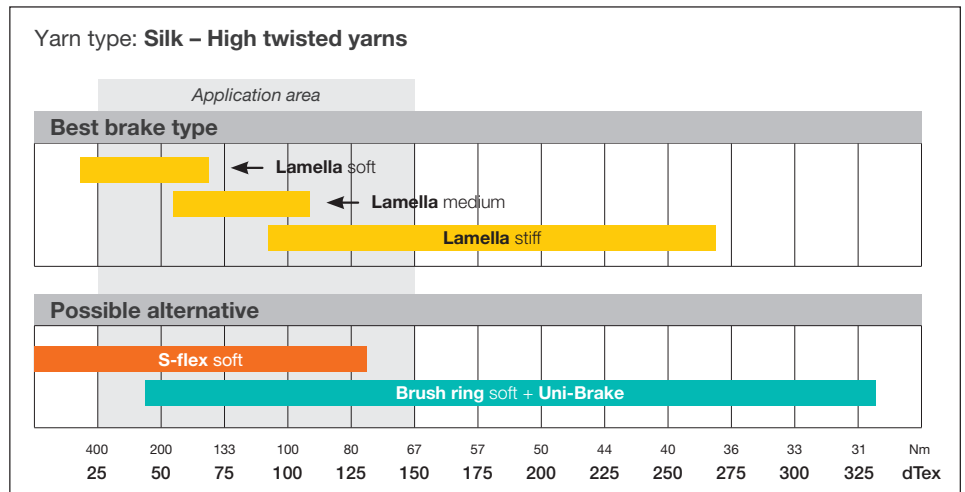

CURTAINS

Imagination is a key element in the creation of fancy fabrics.

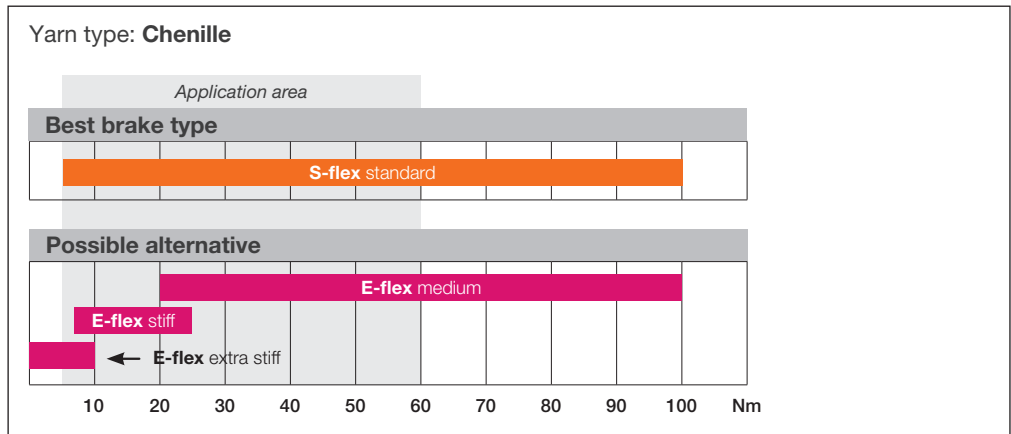
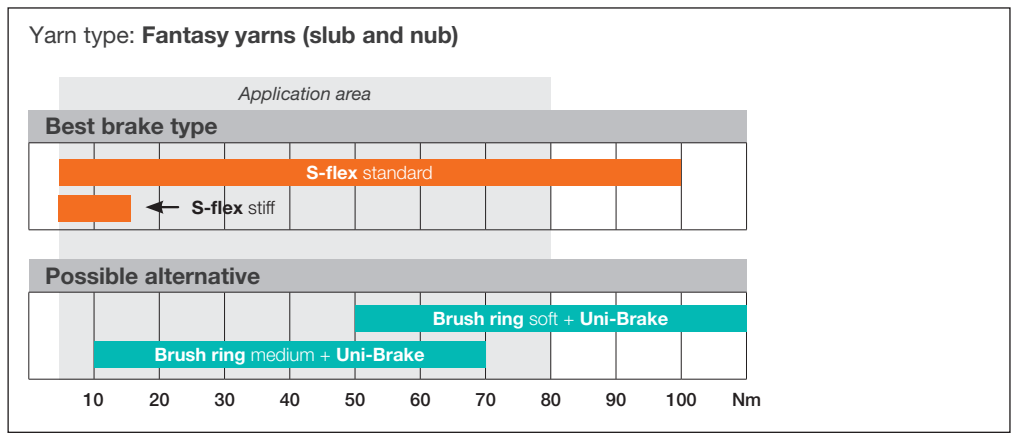
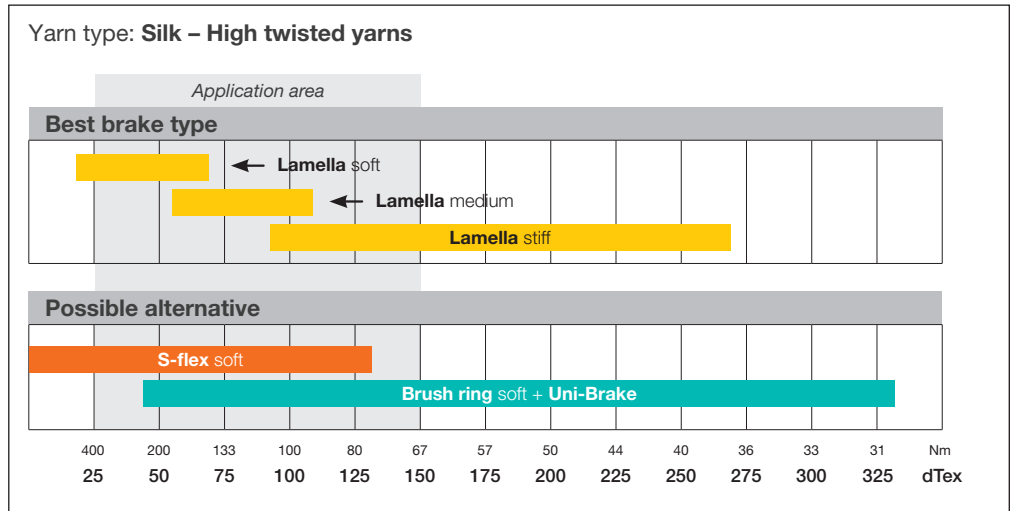

BED SHEETING AND TOWELS

Woven to ensure personal comfort.

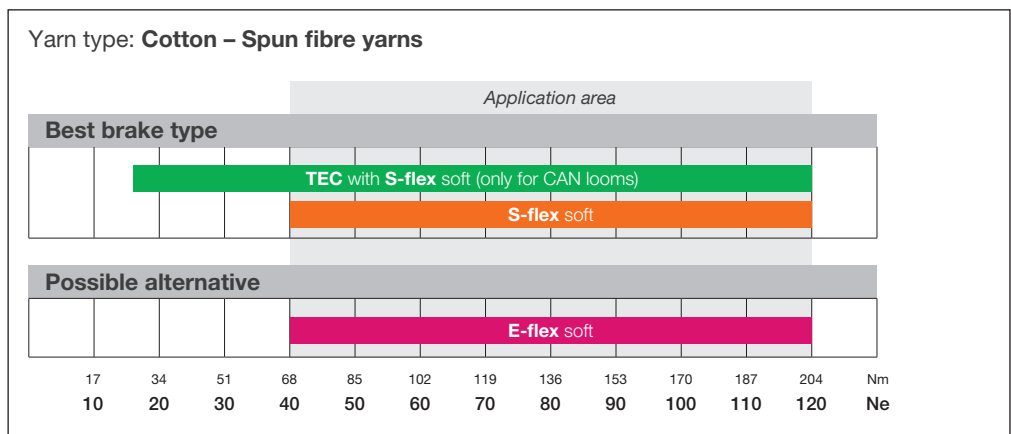

TABLECLOTHS AND HOUSEHOLD LINEN

Natural fibres woven with simplicity to furnish the most elegant tables is an art in itself.

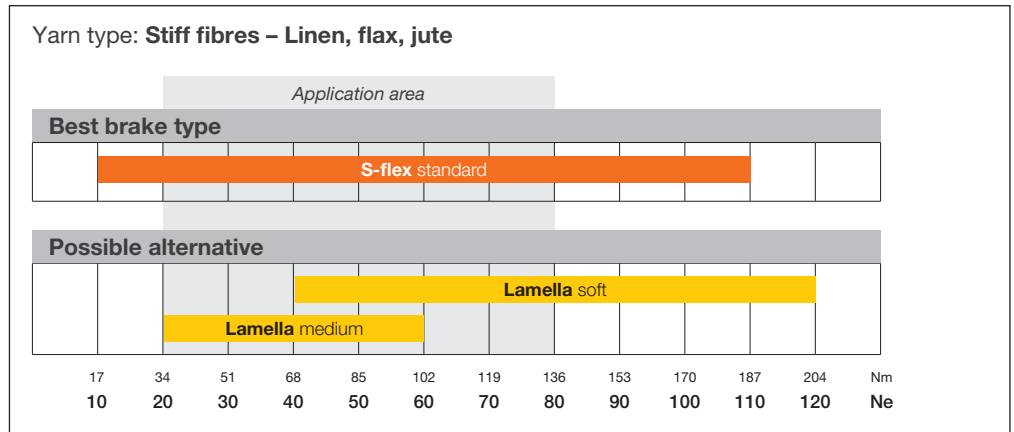

AUTOMOTIVE AND TECHNICAL FABRICS

Numerous variations in yarn types continues to present new challenges, but our wealth of experience ensures we are a perfect partner in the weaving process.

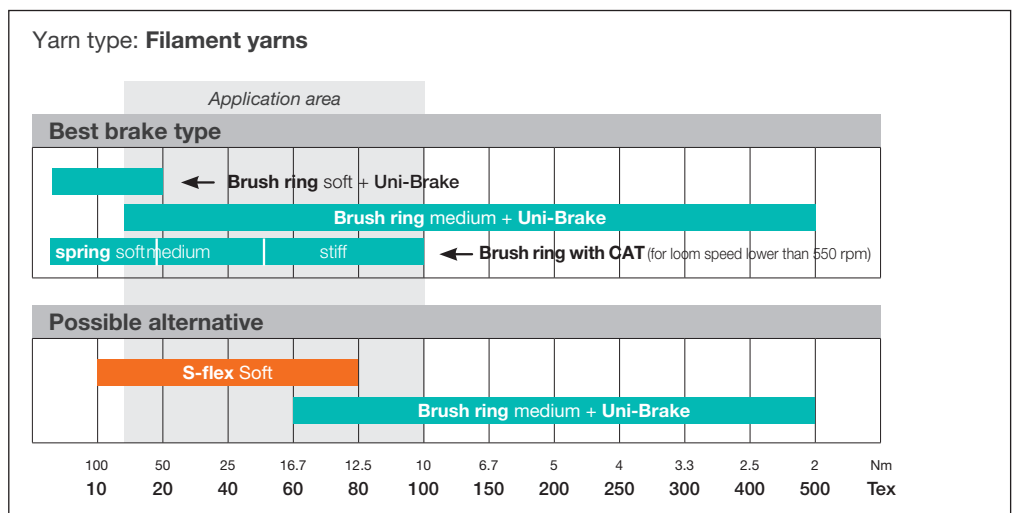
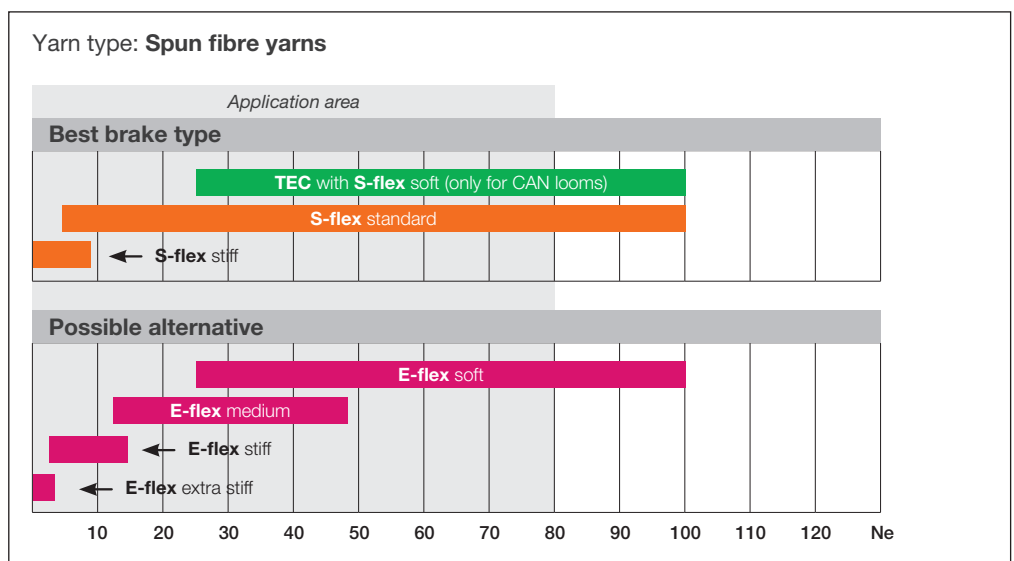



S-Flex Compensating tensioner and Ballon Control

The S-Flex has been developed with a design focused on the combination of “balloon control” and “braking” functionality that covers a range of typical yarns and applications. An optimized braking cone ensures a solution with excellent performance and further improved resistance to wear.

Three versions available, soft, standard and Stiff.

Use with: Luna X3, Chrono X3, XD X3, XD X3 Plus, Stella G2

MOUNTING

Rotating the slide shift lever (1) will detach the brake (2) from the spool body.

NOTE

It is important to use a brake suited for the specific application to prevent reduced life time of the brake.

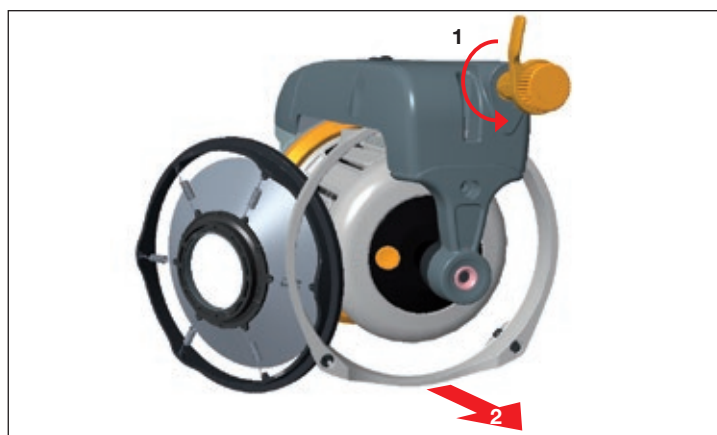

NOSE OUTPUT: S-FLEX 30°

Attach nose output depending on the mounted type of Flex brake to ensure function.

NOTE

The performance of a tensioner can be affected by various factors connected to the specific yarns being used. In case of uncertainty it is recommended to carry out a weft insertion test.

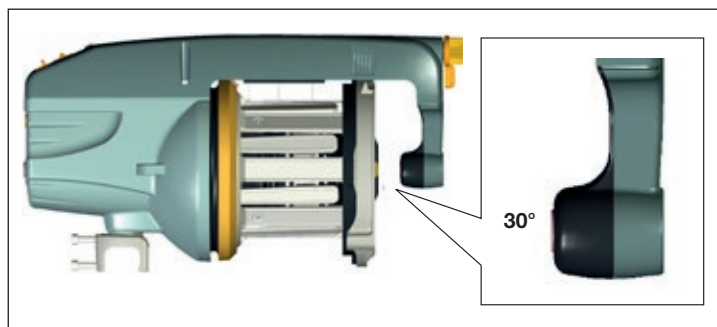

THREADING

- Switch off the feeder
- Align the winding disc eyelet (1).
- Open the brush holder (2)
- Thread the needle all the way through the feeder and output eyelet (3)
- Hook on the yarn on the needle (4)
- Pull the yarn all the way through the feeder
- Restart the feeder

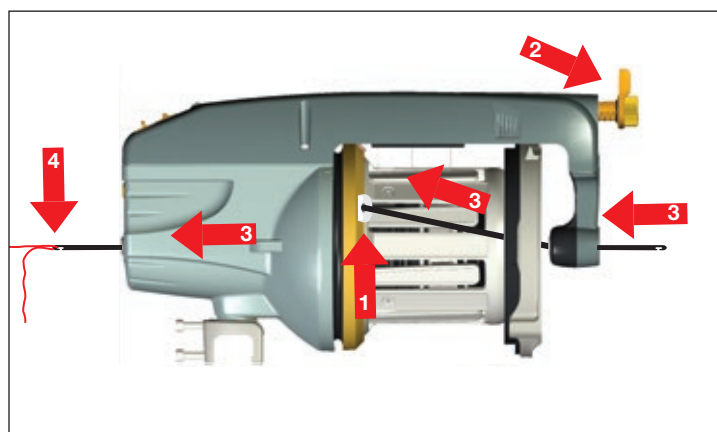

Spool body size:	110 mm	135 mm
Soft	27-0882-101	24-0699-101
Standard	27-0882-002	24-0699-002
Stiff	27-0882-003	24-0699-003

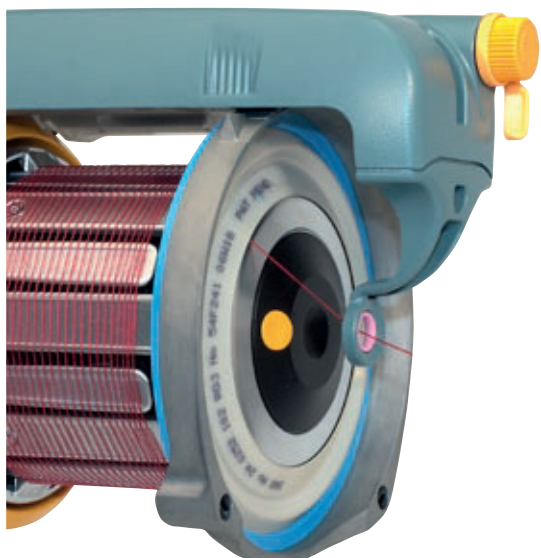

E-Flex Compensating tensioner and Ballon Control

The E-Flex has proven to be a very flexible solution for spun yarns and is appreciated by customers worldwide. This patent protected item continues to be a corner stone for solving tension difficulties on an array of different yarns.

Use with: Luna X3, Chrono X3, XD X3, XD X3 Plus, Stella G2

THREADING

- Switch off the feeder
- Align the winding disc eyelet (1).
- Open the brush holder (2)
- Thread the needle all the way through the feeder and output eyelet (3)
- Hook on the yarn on the needle (4)
- Pull the yarn all the way through the feeder
- Restart the feeder

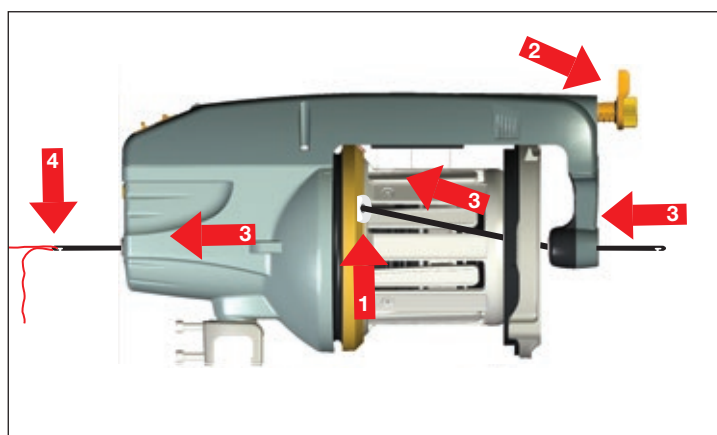

NOSE OUTPUT: E-FLEX BRAKE 42°

Attach nose output depending on the mounted type of Flex brake to ensure function.

NOTE

The performance of a tensioner can be affected by various factors connected to the specific yarns being used. In case of uncertainty it is recommended to carry out a weft insertion test.

*Only for Luna X3, Stella G2

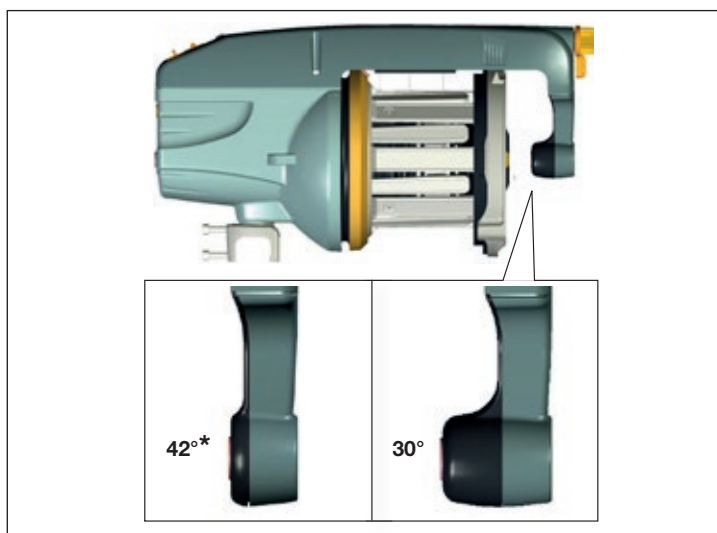

Spool body size:	110 mm	135 mm	110 mm 42°
Soft	27-0534-001 / 54F00220	24-0252-001 / 54F00240	27-0596-001
Medium	27-0573-102 / 54F00221	24-0252-102 / 54F00241	27-0596-102
Stiff	27-0585-002 / 54F00222	24-0281-003 / 54F00242	27-0734-002
X-stiff	27-0885-103 / 54F00224	24-0281-103 / 54F00243	



Lamella Brake

A combination of tensioner and balloon brake widely used for high-twisted yarns and delicate thin yarn applications.

The yarn is handled gently, but at same time the Lamella Brake ensures the required tension level.

Use with: Luna X3, Chrono X3, XD X3 and Stella G2

MOUNTING

Rotating the slide shift lever (1) will detach the brake (2) from the spool body.

NOTE

It is important to use a brake suited for the specific application to prevent reduced life time of the brake.

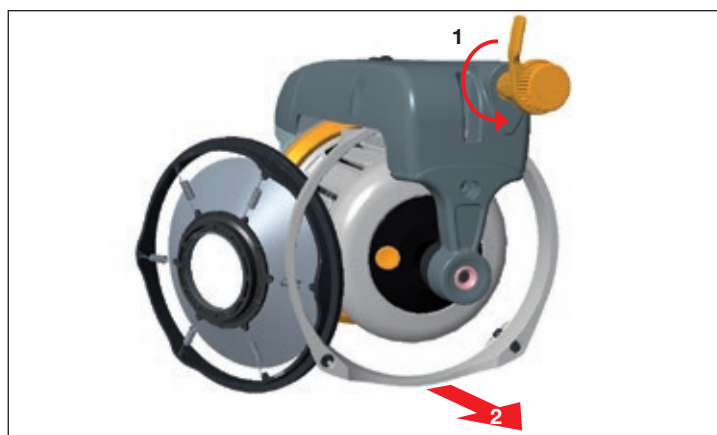

NOSE OUTPUT: LAMELLA CAGE

Using a Lamella cage requires a 42° nose output.



Spool body size:	110 mm	135 mm	135 mm *
Soft, Z-rot.	54T00730	54T00948	24-0702-001
Medium, Z-rot.	54T00731	54T00949	24-0702-002
Stiff, Z-rot.	54T00732	54T00950	24-0702-003

* Including nose piece 42°

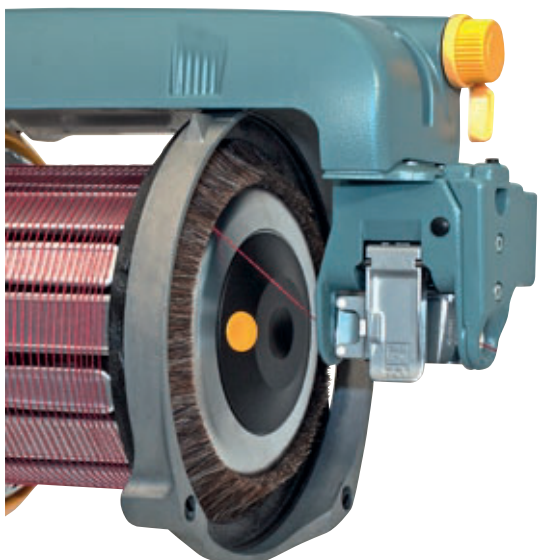

TEC Weaving Machine Controlled (CAN) active tensioner

The TEC is a proven and reliable programmable tensioner suitable for all modern rapier weaving machines equipped with CAN, fully controlled and set via the weaving machine panel. The TEC can also be equipped with optional automatic cleaning.

Use with: Luna X3, Chrono X3 and XD X3

1. USABILITY

The TEC is a programmable tensioner for rapier weaving machines with CAN communication and is suitable for most of the yarn types on the market.

The TEC can be equipped with optional automatic cleaning.

2. SETTING

A. Treading. Lift-up the lever and thread the brake through the eyelets then close the lever.

B. The required tension and timings are set on the loom panel.

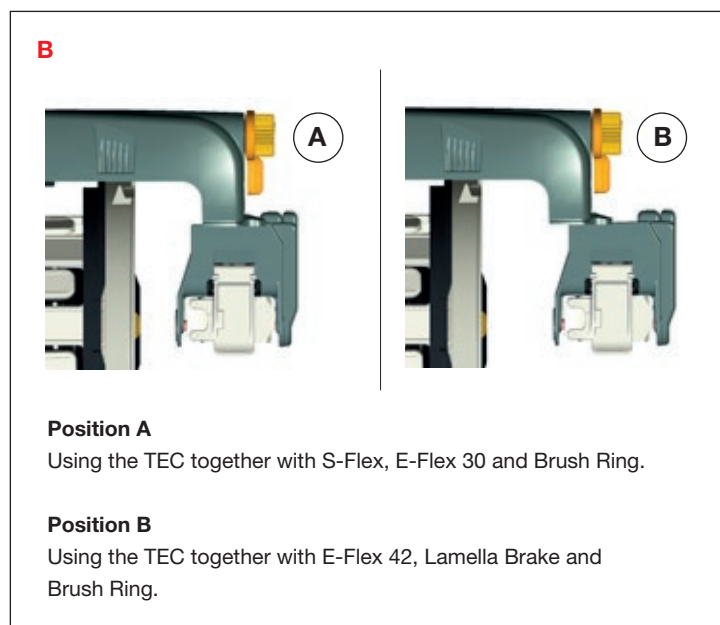
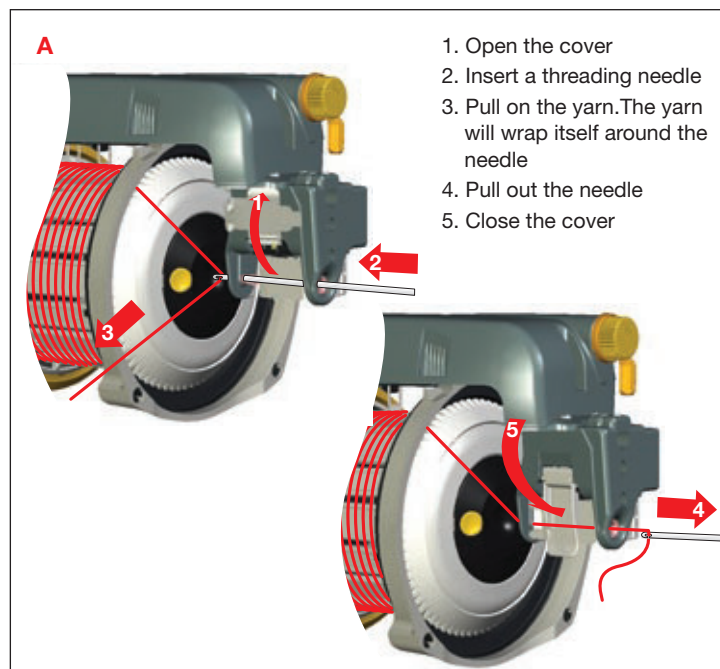

Part numbers:

40-0469-xxxxxx X2 Feeders

40-0662-xxxxxx X3 Feeders

The TEC is available in several different versions, for correct version contact local agent or IRO Service.

Spare parts:

X2 Feeders: See 27-897T-2001-03_SP_Accessories

X3 Feeders: See 24-897L-2001-04_SP_Accessories_X3

CHANGING THE TENSION STRIP

- Open the cover (1)
- Remove the cap (6)
- Tilt the strip to remove (7)
- Tilt the new strip forwards to insert
- Close the cover (5)

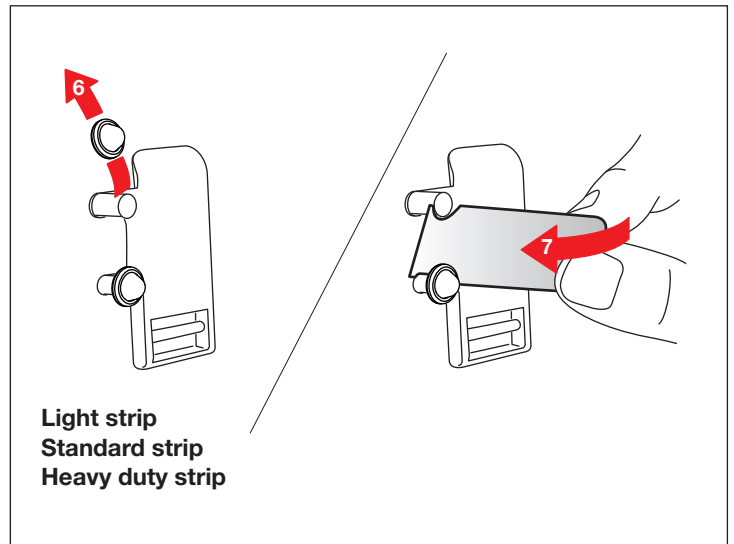



CAT Coaxial Output Tensioner

A compensating tensioner for mid/low speeds, that is suitable for most yarns, but particularly suited to give excellent results with endless filament yarns. Has a high wear resistance. And is a self-cleaning unit. With a ceramic version for extreme wear conditions.

Use with: Luna X3, Chrono X3, XD X3, XD X3 Plus STella G2 and Star G2

1. USABILITY

The CAT is a compensating tensioner for mid/low speeds. Suitable for most yarns but is used especially for endless filament yarns.

2. SETTING

A. Thread the brake through the eyelets.

B. To set the required tension, turn the adjustment wheel in the front.

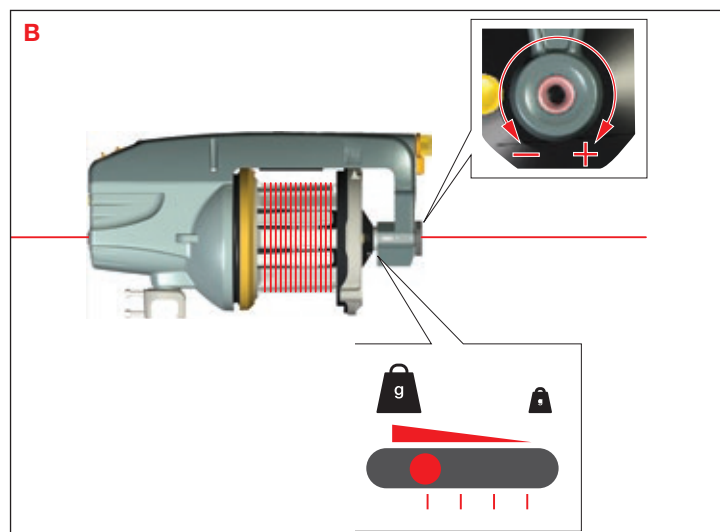
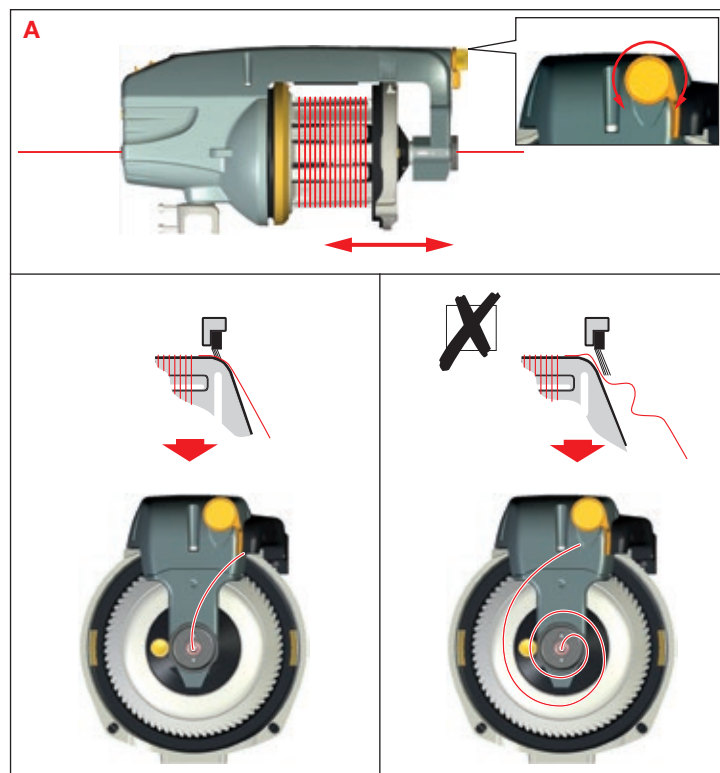

Part numbers:

24-0759-001L	Std. Chrono X3
24-0759-002L	Plasma coated Chrono X3
24-0759-003L	Polished Chrono X3
24-0759-004L	Polished + Plasma coated Chrono X3
24-0759-011L	Std. Luna X3
24-0759-012L	Plasma coated Luna X3
28-0044-000L	Std. G2 Feeders

Spare parts:

X3 Feeders:	See 24-897L-2001-04_SP_Accessories_X3
G2 Feeders:	For G2 feeders the spare parts are included in the spare part list for each feeder.
X2 Feeders:	See 27-897T-2001-03_SP_Accessories

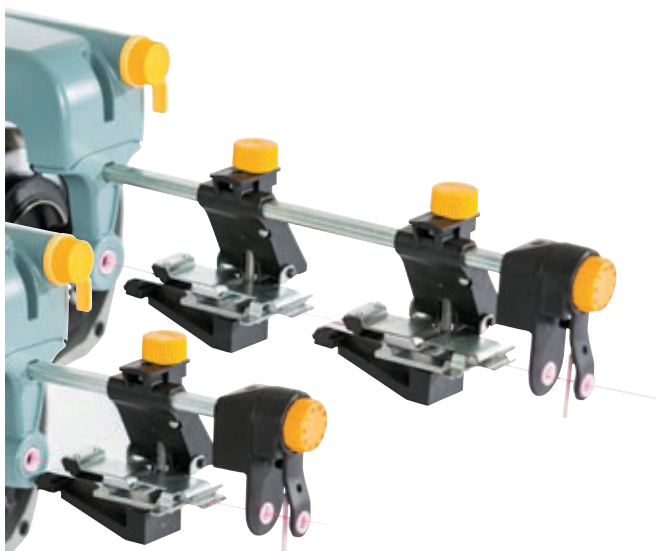

Unibrake

The goal to provide our customers with equipment to produce perfect fabric quality has resulted in our new “Uni-Brake”. The revolutionary Uni-brake surpasses all existing models of traditional leaf tensioners.

High performance, extended longevity and user-friendliness are key elements of the Uni-Brake.

Use with: All type of weft feeders

1. USABILITY

The Uni-Brake is used for both input and output tension, and can handle a wide range of yarns like cotton, fancy, filament and glass fiber yarns, thanks to the wide setting range.

The leaf long breaking length gives reduced stress and tension peaks (occurring due to knots and/or irregularities).

2. SETTING

The required tension is achieved by adjusting the pressure on the upper leaf by turning the knob (1) on the top. Cleaning and threading is performed simply by lifting up the top leaf with the lever (2).

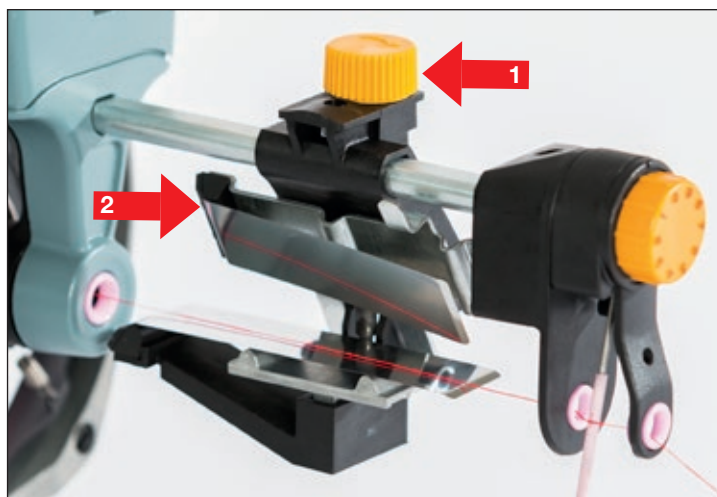

Part numbers:

40-0705-011 Single Uni-Brake with compensator

40-0705-012 Single Uni-Brake with eyelet

40-0712-002 Double Uni-Brake with compensator

40-0715-001 Input Uni-Brake

Spare parts:

40-0703-001 Tensioner leaf upper part compl.

40-0704-001 Tension leaf lower part compl.



Compensator

A compensator is used when the yarn needs to be stretched before weft-insertion. A compensator can be used for most yarns, but is mainly used for twist yarns.

There are versions for mounting on both the input and output sides of a weft-feeder. Combinations of leaf brake assemblies fitted with compensators are available.

Use with: All type of weft feeders

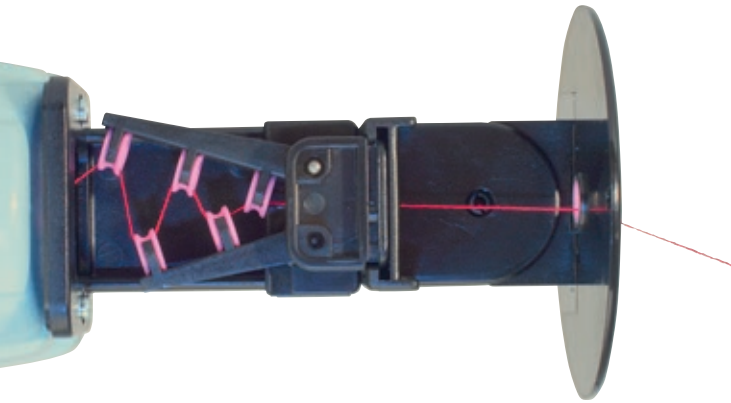

1. USABILITY

A compensator is used to stretch the yarn before weft insertion or as an input tension to the feeder. It can be used for most yarns but mainly used for twisted yarns.

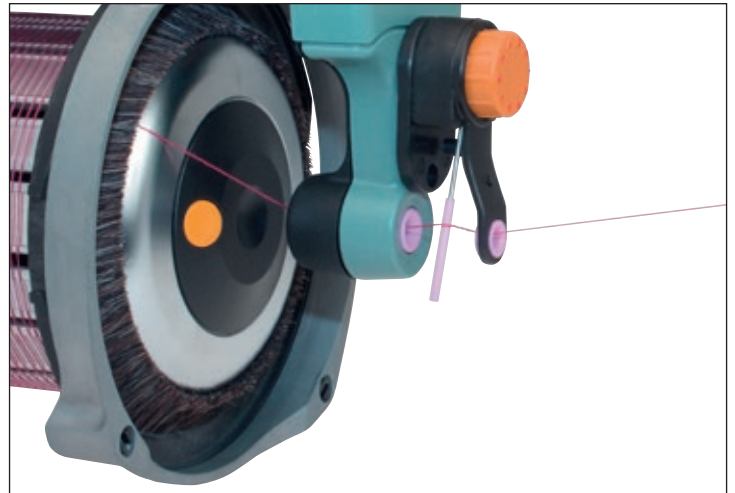

2. SETTING

Input compensator:

To set the required tension use a screwdriver on the top, there are three steps to choose in order to get required tension on the yarn.

Output compensator:

You can choose up to nine different tensions from loose to hard easily by turning the knob in the front.

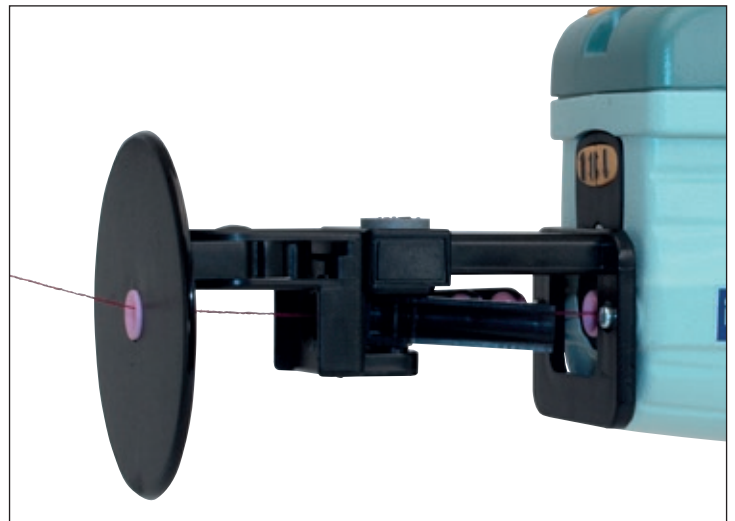

Part numbers:

40-0500-004	Output Compensator
40-0001 / 26B00034	Input compensator
40-0002 / 54R00096	Input compensator w. balloon breaker



Leaf tensioner

The traditional Leaf brake system is very versatile for applying tension to a yarn, and covers most yarns used today.

Use with: All type of weft feeders

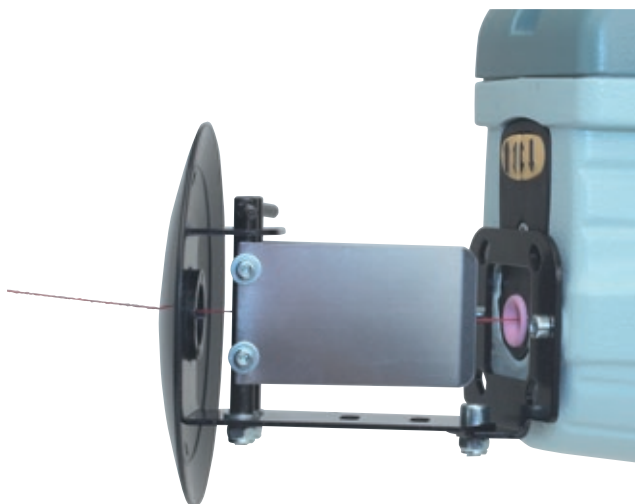

1. USABILITY

The leaf tension is versatile to apply tension to the yarn. To achieve the needed tension it's important to choose the correct thickness on the leaf depending on the yarn count.

Part numbers:

Input tensioner	40-0005-001	001 leaf T= 0,15
Output tensioner	40-0050-015	

Spare parts:

Tension leaf	24E01009	Input T= 0,15
Tension leaf	24E01009	Output T= 0,15

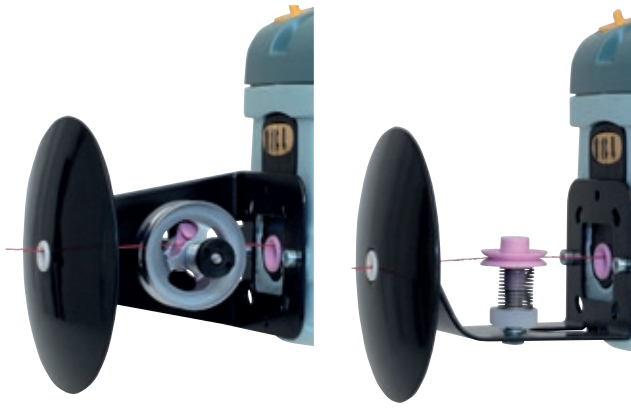

Rotating Disc Tensioner



Exists in two versions, where the metal disc execution is suitable for spun yarns, and the ceramic disc execution is recommended for filament yarns.

This brake type has one major advantage, it is self-cleaning. Mainly used at the input side of a weft feeder.

Use with: All type of weft feeders

1. USABILITY

The rotating disc tensioner exists in two versions, one with metal discs mainly used for spun yarns and the ceramic discs mainly used for filament yarns.

2. SETTING

Thread the brake through the eyelets and into the ceramic slot between the discs. To achieve the required tension turn the plastic nut. To achieve that the discs rotate at a very slow pace mount the disc slightly offset so the yarn will have an angle. If this is set correct you will have a good tension and also the self-cleaning on the discs.

Part numbers:

40-0003	Input metal disc tensioner
40-0003-001	Input metal disc tensioner with polished eyelet
40-0087	Input ceramic disc tensioner with balloon breaker
40-0087-001	Input ceramic disc tensioner with balloon breaker and stiff spring
40-0087-011	Input ceramic disc tensioner with large metal balloon breaker and stiff spring



Twin Around Brake

The Twine-Around Brake is used for yarns which have a twist greater than 2000 turns/meter (crepe, silk, viscose, etc.), and where snarls may form during yarn movement.

Use with: All type of weft feeders

1. USABILITY

The Twine-Around is used for high twisted yarns with more than 2000 turns/meter.

2. SETTING

Thread the brake through the eyelets (1) and then turn the ceramic tube (2) by the front gable until you reach required tension.

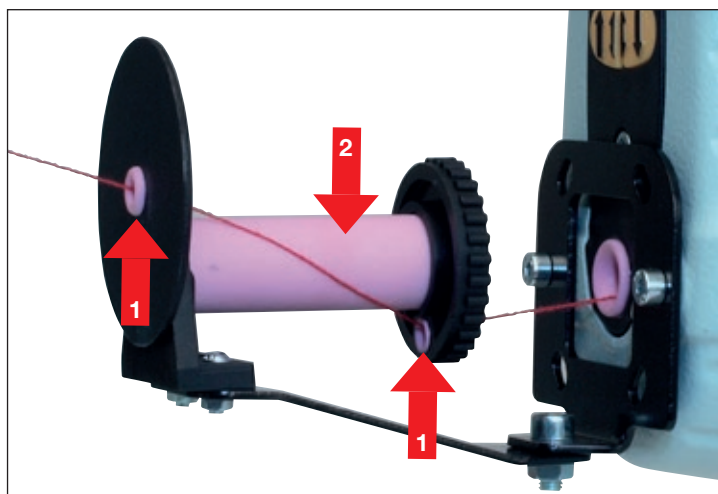

Part numbers:

54R000097

Spare parts:

54R00309 Rod tensioner

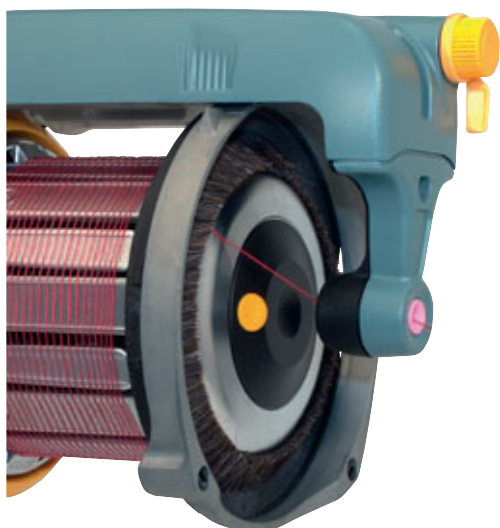

Brush rings



The traditional brush element used for balloon control when the yarn is inserted into the weaving machine, exists in many different versions, including: Direction orientated bristles for the optimum performance, different bristle materials and a range of bristle thicknesses.

Use with: All type of weft feeders

Alternative for Luna X3, Chrono X3, XD X3. Stella G2 and Star G2

BRUSH RING ALTERNATIVE

Z for Z-rotation

S for S-rotation

Straight for Z and S rotation

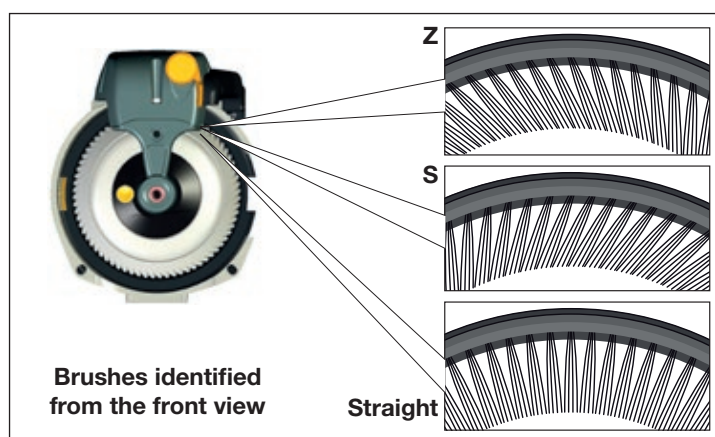

BRUSH MOUNTING

Rotating the slide shift lever (1) will detach the brush holder (2) from the spool body.

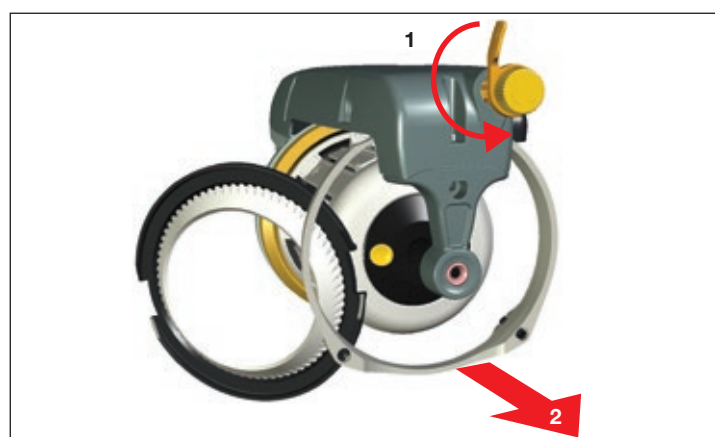

Ensure that the brush ring is correctly positioned (3) when attaching.

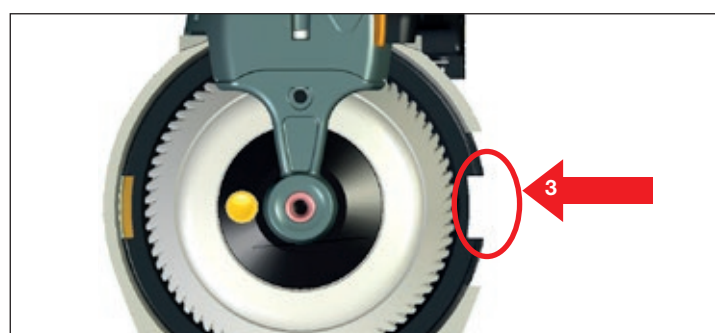

Optional for XD X3 Plus and HD X3

BRUSH RING ALTERNATIVE

Z for Z-rotation

S for S-rotation

Straight for Z and S rotation

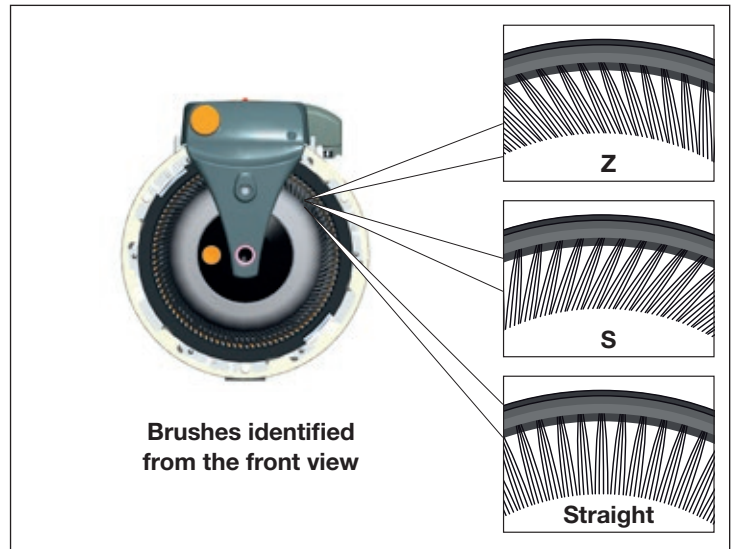

MOUNTING

Rotating the slide shift lever (1) will detach the brake from the spool body.



Ensure that the brush ring is correctly positioned (2) when attaching.

NOTE

It is important to use a brake suited for the specific application to prevent reduced life time of the brake.

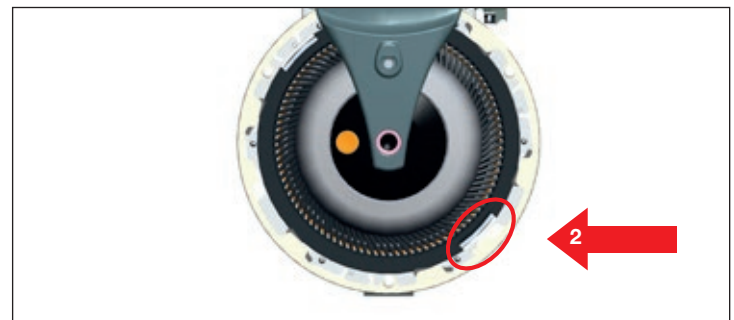

NOSE OUTPUT: FLEX BRAKE for XD X3 PLUS and HD X3

Attach nose output depending on the mounted type of Flex brake to ensure function.

NOTE

The performance of a tensioner can be affected by various factors connected to the specific yarns being used. In case of uncertainty it is recommended to carry out a weft insertion test.

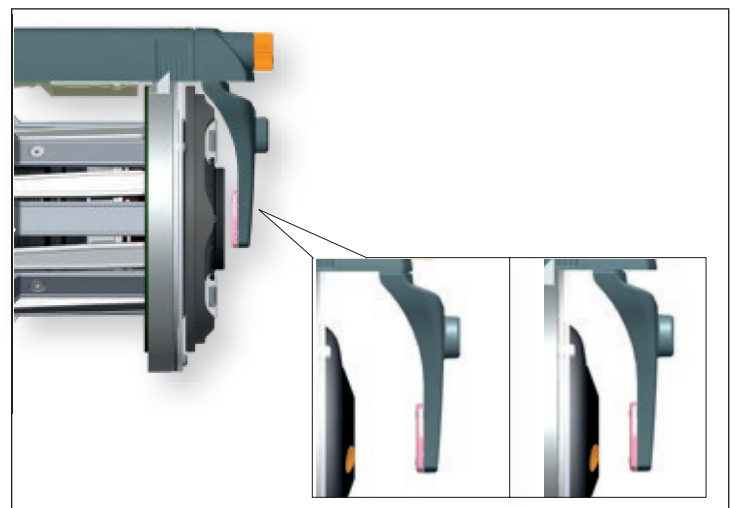



PosiFlex



The PosiFlex for Picanol is a fast reacting, programmable weft tensioner system that automatically adjusts to the optimum tension for the complete weft insertion cycle according to the pre-set level required. By the use of an integrated electromagnet a specially developed flex brake ensures the correct tension at all times.

Use with: Chrono X3, XD X3

INSTALLATION OF THE POSIFLEX

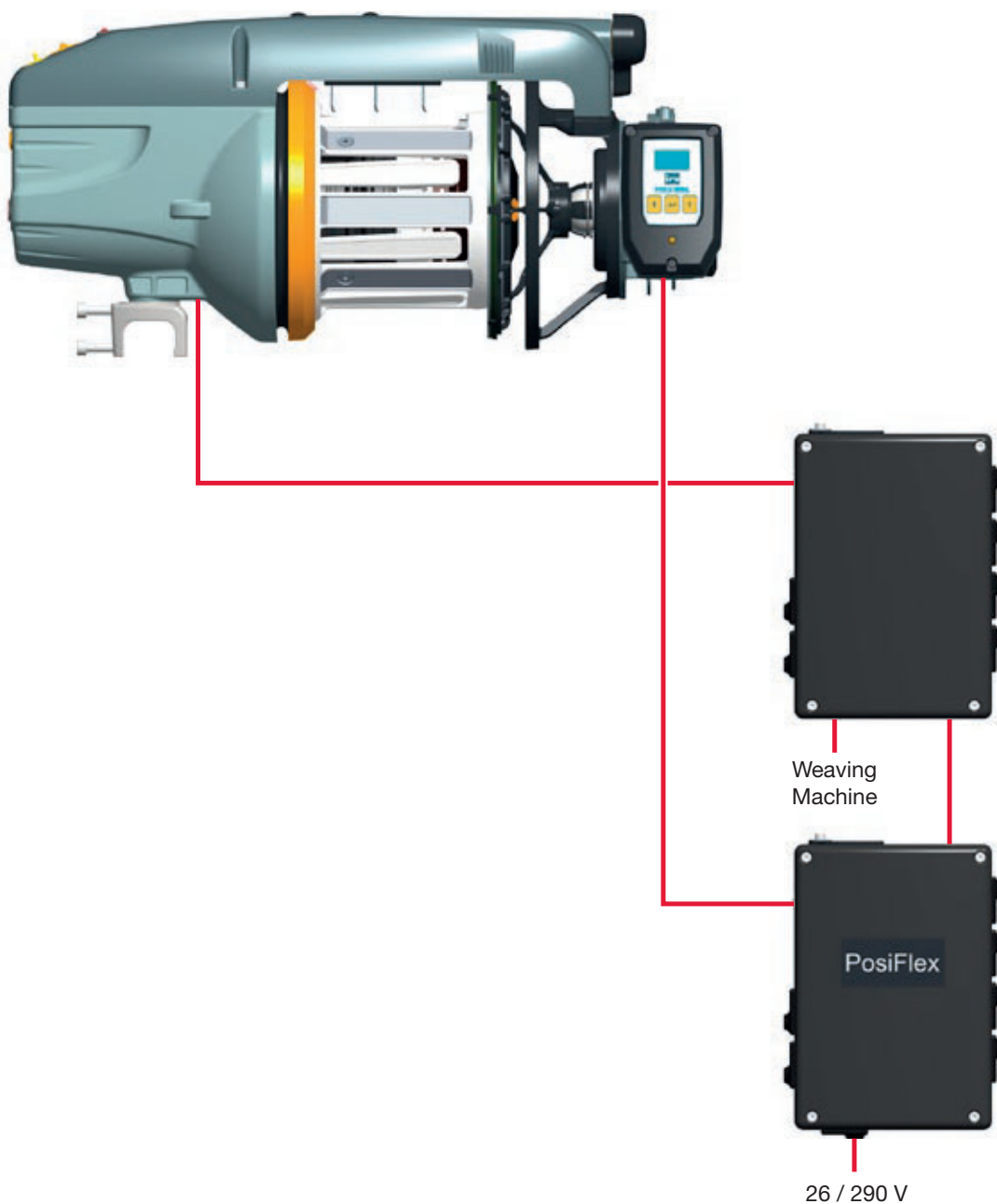

The user-friendly settings are easy to program using the easily accessible integrated panel.

The major advantage with this system is that there is only one setting for the weft tension. With a conventional “brush and brake” set-up, there are two settings that influence the weft tension.

- A. PosiFlex display
- B. Arrow up
- C. Arrow down
- D. Enter



REPLACE THE BRAKE ELEMENT “UNIFLEX”

1. Open the quick release.
2. Remove the UniFlex.
3. Mount a new UniFlex

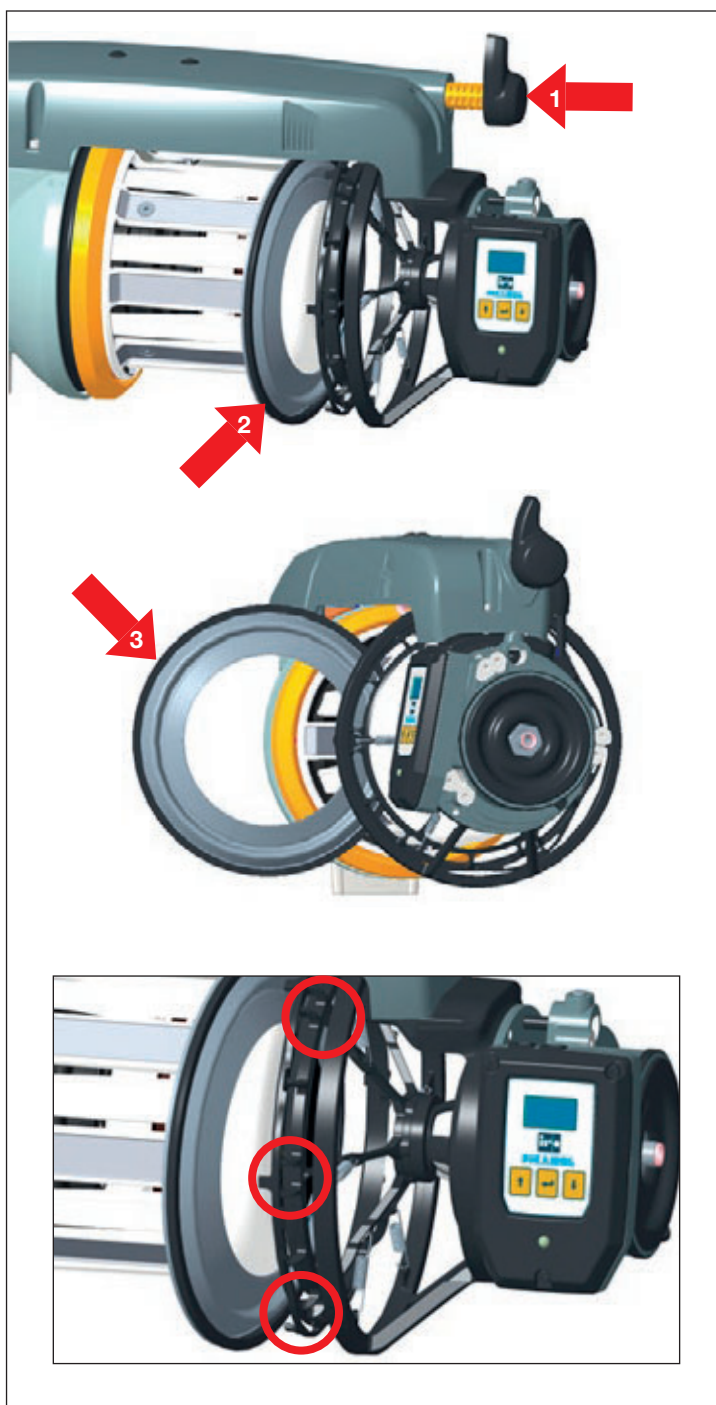

NOTE

Secure all **SIX** fixation points for the UniFlex when changing.

THREADING OF THE POSIFLEX

1. Open the quick release.
2. Thread the yarn using a threading needle

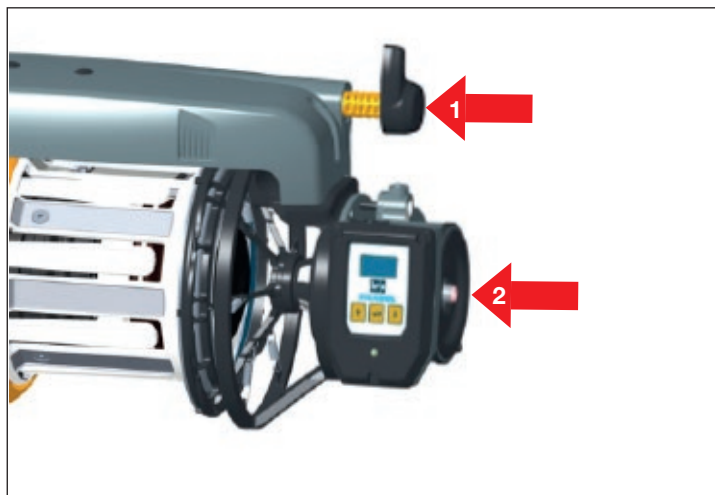

USE OF POSIFLEX

1. Press the enter button	2. The display change to white	3. Press the enter again	4. The display became black and the PosiFlex will open	5. After the threading press the enter again to close the PosiFlex

NOTE

After 30 sec the PosiFlex will automatically close

SETTING, “CHANGE PROFILE”

1. Use the arrow up or down to choose the proper profile to use during the weaving process	2. The choose profile will light up in the display	3. Confirm the profile with the enter button



ATC-W Automatic Tension Control

For weaving machines equipped with CAN communication weft feeders.

The unique function of ATC-W is to automatically maintain consistent yarn tension at a pre-determined level unaffected by variable external factors such as bobbin size or yarn quality.

The required tension is easily set and monitored on the ATC display. Once set, the system constantly regulates itself ensuring consistent yarn tension during the weaving process.

Use with: Luna X3, Chrono X3, XD X3

- A. ATC-W Motor with display
- B. Function Button and Knob
- C. Compensator
- D. Sensor head

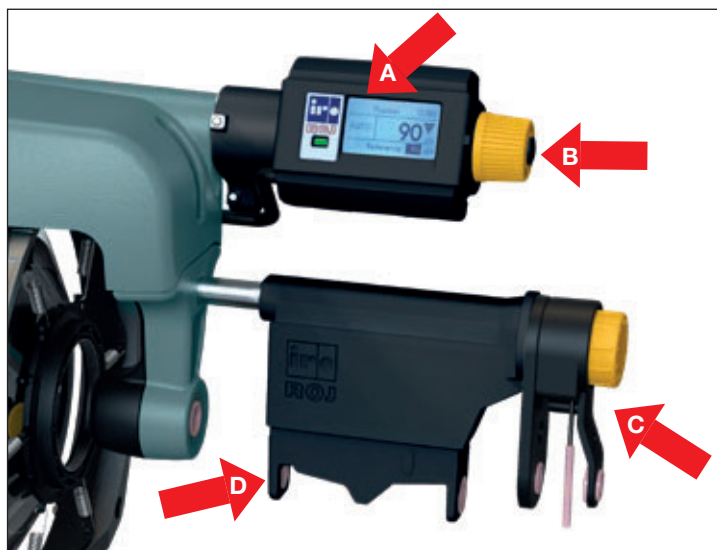

INSTALLATION OF ATC-W

E-learning, see www.roj.com/roj-academy

The Mounting Rod and Compensator are included in the kit for the installation of the ATC-W.

Tool required (not included):

- Torx T6 screwdriver
- Allen key Size 3 screwdriver

NOTE

For special applications please contact IRO/ROJ service for advice.



Part numbers:

40-0860-001 ATC-W for Luna X3

40-0860-002 ATC-W for Chrono X3 / XD X3

1. BEFORE INSTALLATION

Before starting the installation, switch off the power supply to the feeder(s) and loom.

Set the braking holder adjustment knob so that the braking holder is completely flush with the end of the spool-body – as shown by the red arrow.



2. START INSTALLATION

Fit the ATC-W motor (A) unit onto the quick release of the feeder.

Fit the metal retaining ring behind the quick release (B) and fix into place using the screws provided (C, D).

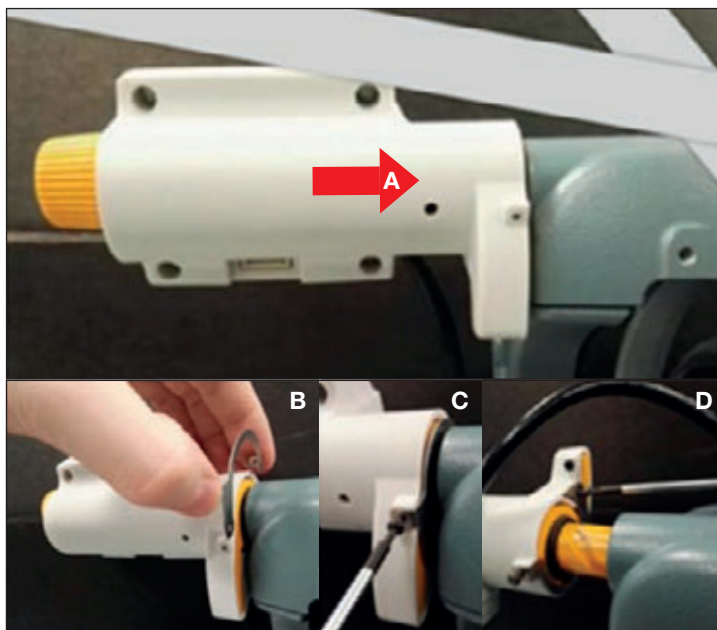

Connect the ATC-W motor cable to the accessory connector socket of the feeder.



Mount the ATC-W sensor onto the feeder and fix into place as shown in the picture.





Connect the ATC-W sensor cable to the ATC-W motor unit.



2. ENTER THE SETTINGS MENU

Switch ON the loom power supply.

Enter the default password provided by ROJ/IRO service enables access to the “Enhanced Level.

Default password: 12345

Alarm list, see page M-8.



Rotate the knob (A) to change the parameter.

Push the button (B) to enter into the first level of the menu.

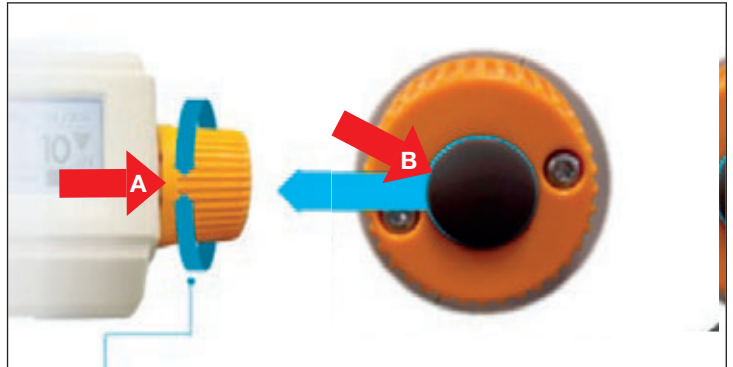

3. SETTINGS

Here you can set the basic features.



Brake control mode

Choose between Automatic or Manual in the Brake Control mode menu.

NOTE

There is a short-cut from the HOME PAGE to swap between MAN and AUTO by pressing and holding the button for 3 seconds.



Manual Mode

In MANUAL mode the brake adjustment knob is used to position the brake holder, with 1 click either increasing or decreasing the position by 1 step, depending on the direction the knob is turned.

NOTE

Manual mode is for setting only.



Automatic Mode

In AUTOMATIC mode the brake adjustment knob sets the reference tension, with 1 click either increasing or decreasing the tension by 1cN, depending on the direction the knob is turned.

NOTE

Automatic mode is for running mode.



Keylock

The key symbol is displayed in the top left corner of the home page with ATC-W is locked.



If the Keylock is "OFF" and the user accidentally touches the brake adjustment knob, then the brake holder position (MAN mode) or the reference tension (AUTO mode) could be unintentionally changed.



When keylock is “ON” this engages the “Auto key lock” function.

This means after a period of inactivity of 20 seconds the functionality of the brake adjustment knob is disabled and the user has to push the button to unlock it again.



Alarm menu

An Alarm can usually be reset by pushing the button when an alarm message is shown on the home page.

The alarm status can be checked in the alarm menu if the reset does not resolve the issue.



According to the alarm type the RED LED will blink either fast or slow.

Pushing the button resets the alarm and the display reverts back to the home page.

Alarm list, see page M-8.



Info menu

Here technical information can be found, which is useful if technical assistance is needed.”



SW version

In this submenu you can find the ATC-W software, hardware and bootloader versions.”



Password

Entering the password unlocks sub-menus / features designed to be used by qualified technicians.



A 5 digit password supplied by the IRO/ROJ service department is needed to access the Enhanced level options.



Enhanced level allows access to the options necessary to install ATC-W.



4. INTRODUCTION TO THE DISPLAY

A. **Operation mode.** Manual (MAN) or Automatic (AUTO).

B. **Tension.** As per the highlighted arrow, the display shows the actual measured tension.

The symbol blinks when the motor is in operation.

C. **Brake holder position.** As per the highlighted arrow, the display shows the brake holder position out of a possible 200 positions e.g. 180 / 200.

D. **Target tension (Reference).** As per the highlighted arrow, the display shows the target or reference tension in AUTO mode the ATC-W has been set to maintain.

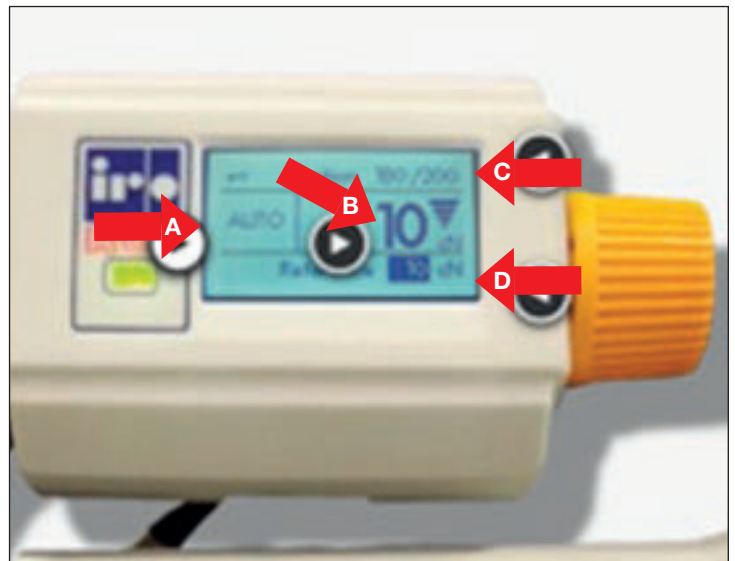



5. LED INDICATOR

RED LED

ATC-W is in bootloader mode: RED LED will blink fast.

ATC-W is in boot mode which occurs during a SW update or after a SW update failure.

ATC-W alarm warning: RED LED will blink fast or slow depending on alarm type.

ORANGE LED

ATC-W is in MANUAL mode: ORANGE LED remains illuminated.

GREEN LED

ATC-W is in AUTO mode: GREEN LED remains illuminated.

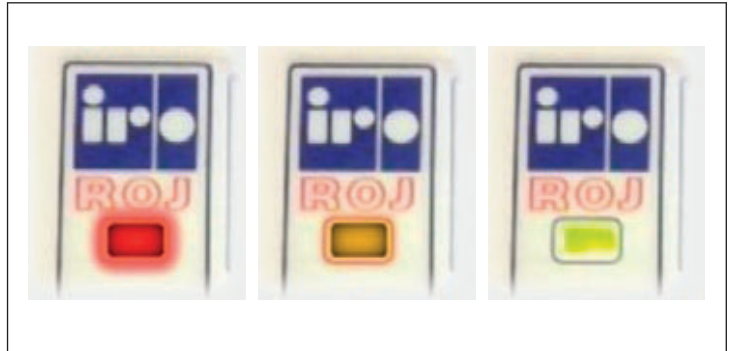

6. WELCOME SCREEN

Appears for about 5 seconds, then the homepage is shown.



7. ALARM LIST

Table of the alarm currently implemented, kind of alarm, relative LED behavior blinking and feeder action.

Error	Description	Kind of alarm	LED blinking
Missing parameters	Missing parameters from the loom. ATC-W stops to work. Pushing the button, the alarm is not reset. The control is disabled in AUTO mode. Anyway it is possible to handle the ATC-W in manual mode. Errors is still present in Alarm menu.	Warning	Slow
Over current	A motor overcurrent event occurs during the motor driving. ATC-W stops to work and motor is stopped. Button resets the alarm.	Fatal	Fast
Motor locked	A motor lock event occurs during the motor driving. ATC-W stops to work and motor is stopped. Button resets the alarm.	Fatal	Fast
Tensionmeter Failure	In case of the following conditions – Tensionmeter out of calibration or broken – Tensionmeter not plugged – Offset calibration failure ATC-W stops to work. Button resets the alarm.	Fatal	Fast
Anglebus Error	Angle bus from Loom is mission	Fatal	Fast
Yarn missing	Yarn is outside the sensor guide. ATC-W stops to work. Button resets the alarm.	Fatal	Fast
Tension out of range	In the reference tension is not reached within a certain number of picks, with a certain tolerance. Alarm is reset automatically at every loom start in case the tension error is in tolerance. In MANUAL mode the motor can be driven.	Warning	Slow
Zero position required	In case of incongruous brake holder position. It is required the user / service to apply the zero holder procedure.	Warning	Slow
E2PROM error	In case of E2PROM writing error.	Fatal	Fast
Default reload	At the power supply ON, the default valves in E2PROM are reloaded.	Fatal	Fast

For any kind of alarm, the feeder stops the loom or not according the weaving machine protocol.



TED Tension Display

This innovative and unique product makes it possible to reproduce weft tension settings from one machine to another enabling a fast start up the next time the same article is woven.

Use with: Luna X3, Chrono X3, XD X3

TED (Tension Display) is an accessory designed to fit IRO/ROJ Luna X3 and Chrono X3 rapier feeders in combination with S-flex tensioners. The display on the device shows the position of the S-flex holder in relation to the zero position making it very simple to adjust the S-flex to the correct position.

- A. TED Display
- B. LED indicator
- C. Push button
- D. S-flex holder position adjustment knob
- E. Quick release handle (integrated into the TED body)

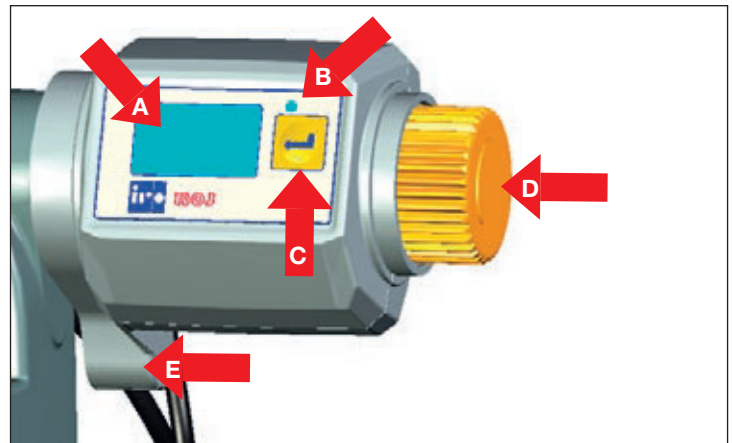

TED TENSION DISPLAY INSTALLATION

How to equip an existing Luna X3 / Chrono X3 with TED, Tension Display.

1. Remove the top cover from the feeder.
2. Remove the sensor system
3. Move the brushing holder by turning the adjustment knob counter-clockwise until fully open. This will make it possible to access the circlip at the end of the adjustment screw.
4. Remove the circlip.

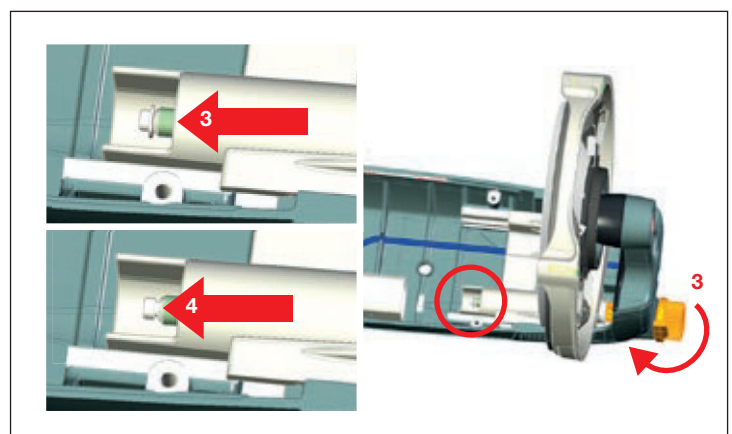
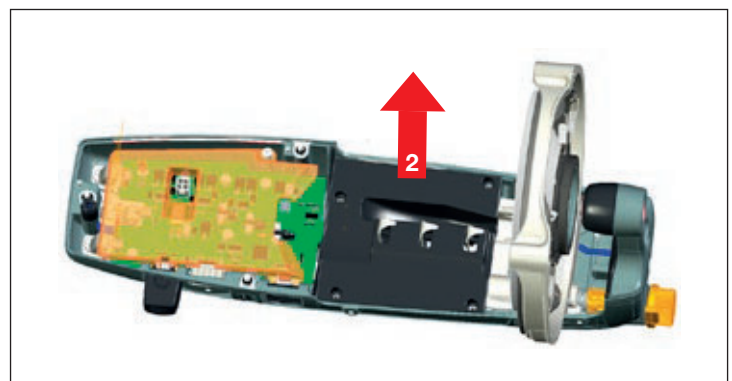

5. Remove the adjustment screw from the top cover by turning the brushing adjustment knob clockwise.



6. Install the TED device.



7. Turn the TED brushing adjustment knob until the tip of the screw is visible to make the circlip groove accessible.

8. Refit the circlip

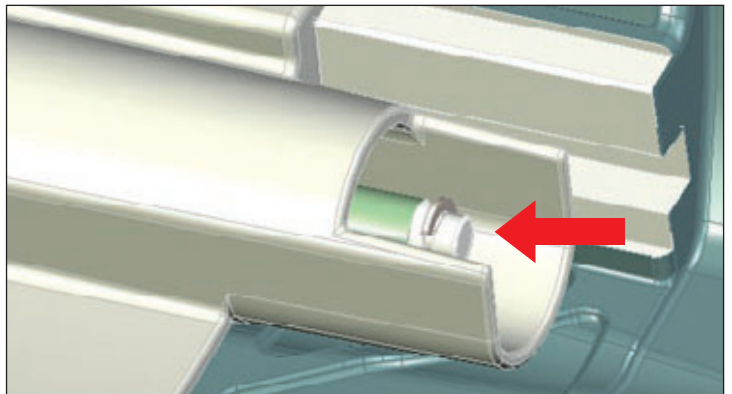

9. Reassemble the sensor system and top cover and refit onto the feeder

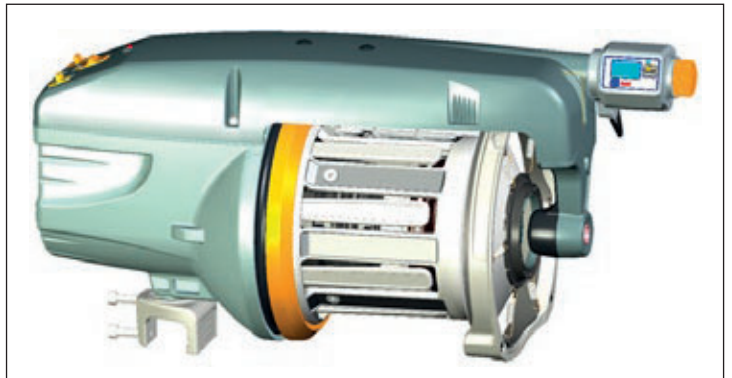

10. Connect the TED cable to the feeder accessory outlet socket and mount the protective cable channel cover.



NOTE

In case a TEC Brake is also being used:

Use the split cable to connect both TED (A) and TEC (B) to the feeder accessory outlet connector (C) according to the connection diagram. Then assemble the protective cable channel cover to the side of the feeder.

Refer to the TED User Manual for zero setting instructions.

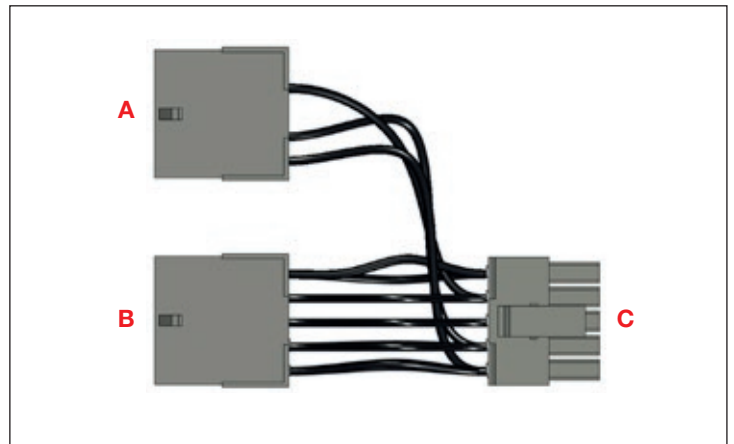

1. SETTING THE ZERO POSITION

TED displays the position of the S-flex holder in relation to the zero position, which is the position where the S-flex braking element touches the front part of the feeder spool-body.

The zero position needs to be set manually when a new S-flex is installed.

Zero position setting:

1. Install the S-flex and adjust the position of the S-flex holder by turning the adjustment knob counter-clockwise to an open position (visual clearance between the S-flex brake element and the front part of the spool-body).
2. Turn the S-flex holder adjustment knob clockwise until the S-flex brake element touches the front part of the spool-body.
3. Press the TED push button for a couple of seconds - the display flashes "0?". Confirm the zero setting using the push button within one second. The red LED lights up when the push button is activated.
4. If the zero setting has been performed correctly, the TED display now shows a value of "0" to confirm that the device is set to the zero position.

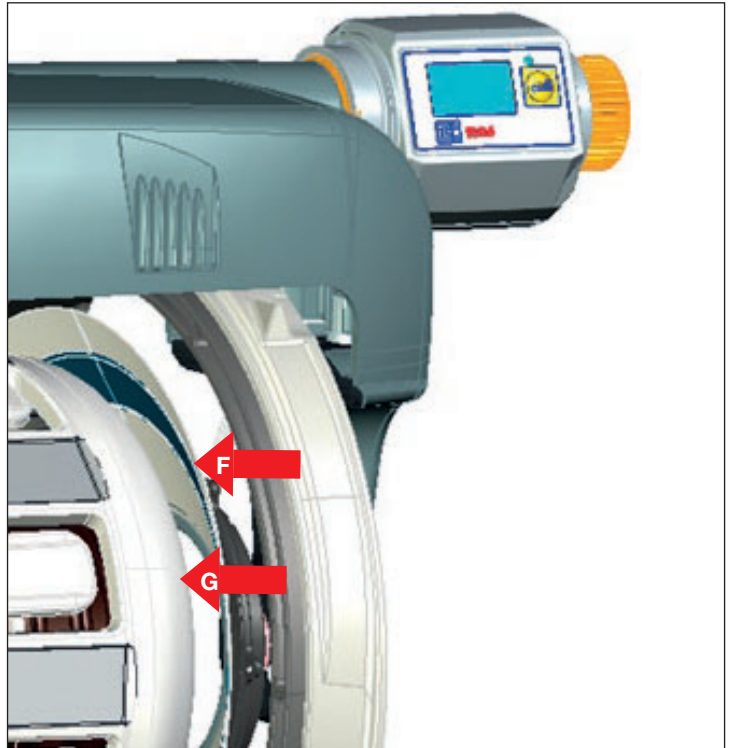

2. ADJUSTMENT OF THE S-FLEX HOLDER POSITION

Turn the S-flex holder adjustment knob clockwise to increase the tension.

The new position is automatically displayed by the TED device.

By turning the S-flex holder adjustment knob counter-clockwise the tension is decreased.

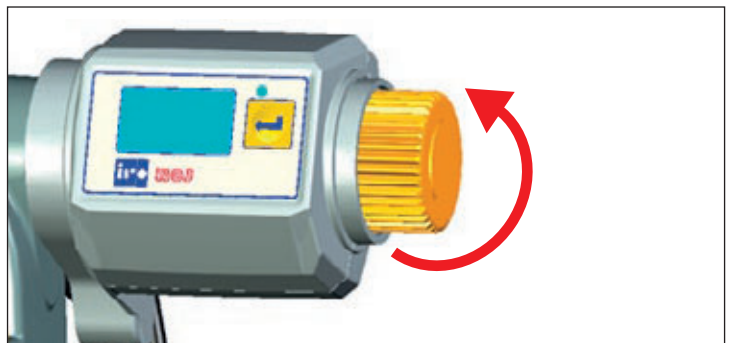

3. QUICK RELEASE FUNCTION

The quick release function is performed by turning the complete TED unit counter-clockwise.

When returning the device to its correct working position please make sure to turn the unit until the TED locks into position.



4. BACK LIGHT ACTIVATION

The display backlight dims automatically after one minute activation. Reactivate the backlight by pressing the push button.

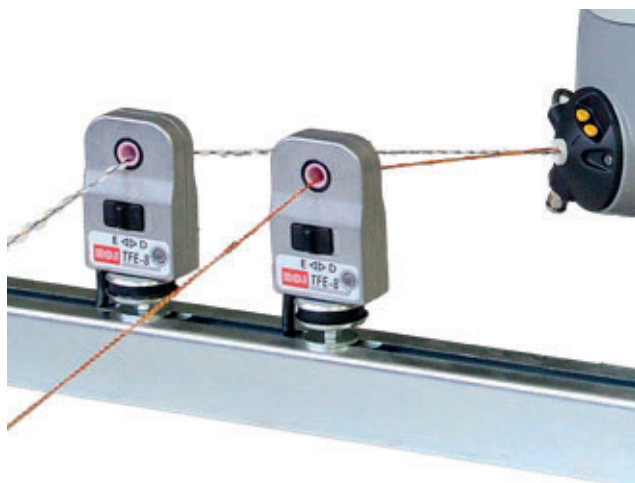

Piezo Sensor



External piezo sensors for multiple yarn insertions. The multi yarn sensor system can control a combination of up to eight wefts divided between up to four weft-feeders at the same time.

The TFE-8 Piezo sensors ensure a high level of sensitivity with a minimum increase in yarn tension and the compact design makes the system extremely simple to install. This system is available both for rapier and air jet feeders.

Use with: Luna X3, Chrono X3, XD X3 and Picanol Airjet

1. USABILITY

The Piezo sensor is used to monitoring yarn breaks on the weft yarn.

The Sensor is available for both Air jet and Rapier feeders. In case of installation at feeder entry; we have a that includes a mounting bracket and the sensor.

2. SETTING

Connect the sensor either to the feeder or in to the concentrator box, concentrator box is used if more than two yarns is used for one feeder.

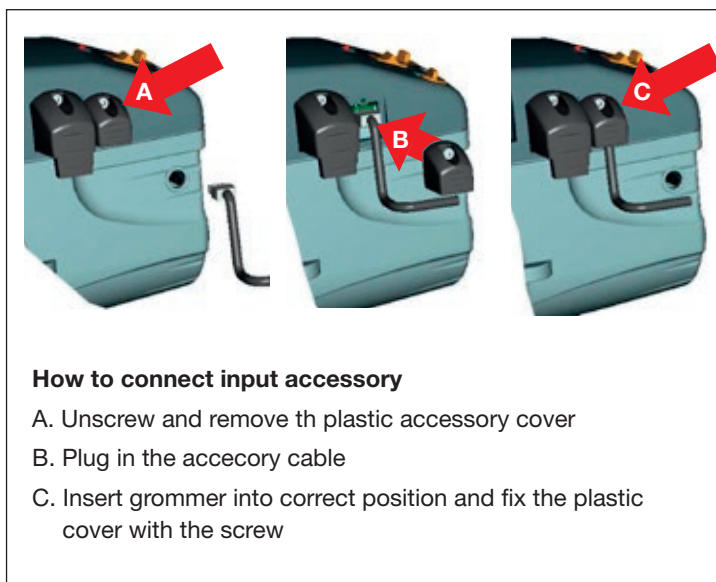

How to connect input accessory

- A. Unscrew and remove the plastic accessory cover
- B. Plug in the accessory cable
- C. Insert grommet into correct position and fix the plastic cover with the screw

Part numbers:

31-1135	Yarn break sensor complete	Air jet
53D00025R	(4 meter cable) Yarn break sensor	Rapier
53D00026R	(0,5 meter cable) Yarn break sensor	Rapier
56T00199	KIT Rapier (includes Yarn break sensor 53D00026R and Bracket 56T000134)	
56T00134	Bracket	

Spare parts:

31-1132	Yarn break sensor	Air jet
53D00025R	Yarn break sensor	Rapier
53D00026R	Yarn break sensor	Rapier
56T00134	Bracket	

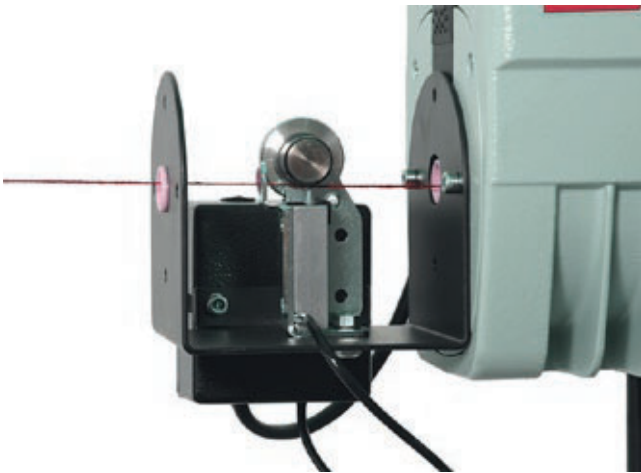

X3 Knot Sensor

The Knot Sensor, for simple and precise monitoring of knots in the weft. The detector/sensor is integrated with the feeder's CAN communication network giving immediate reaction to irregularities, but can also be used with stand-alone systems.

The virtually contact-free design of the detector ensures that no additional tension is applied to the yarn even when weaving at maximum insertion velocity.

Use with: Luna X3, Chrono X3, XD X3

The unit is easily installed and can be used together with all the input and output components in the system.

- Yarn-count range: Nm 40 – Nm 150
- Easily adjusted to the required yarn count
- No wearing parts
- Power supply and signal directly from the feeder.

Simple “plug and play” installation, which when completed looks like the picture on the right



1. MOUNTING

Mount Knot Sensor to rear of feeder using the 2 x 3mm Allen Screws.

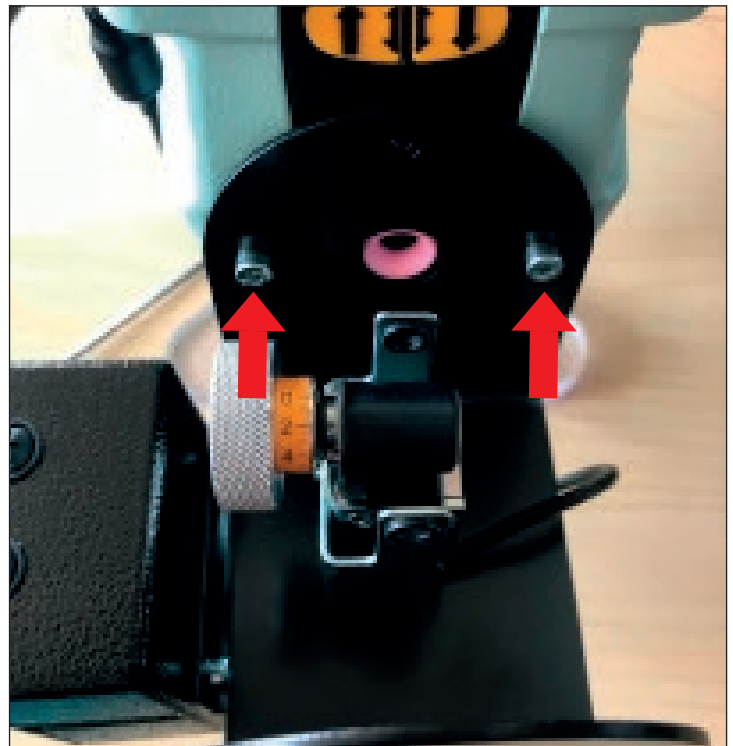

Part number:

40-0572-302 X3 Knot Sensor

Remove Plug Socket Cover where Knot Sensor “plugs” into and plug in the signal / power cable.



Replace Cover and Dust Protection Insert using the 3mm Allen Fixing Screw.

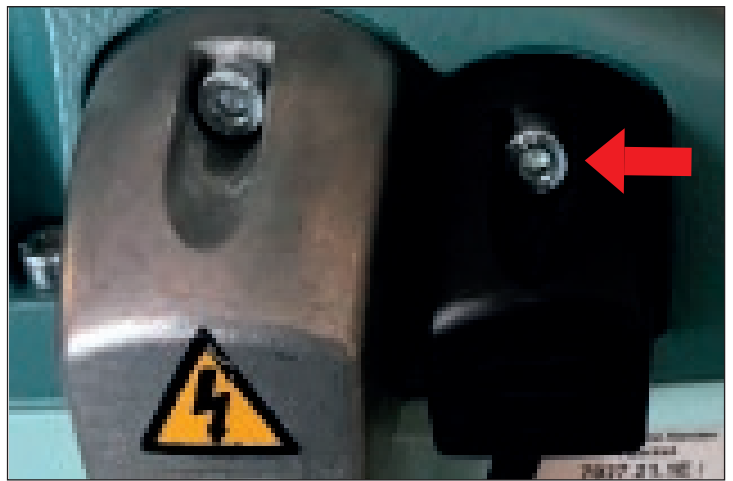
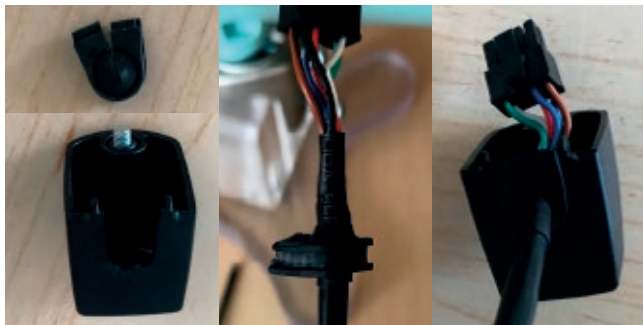

2. THREADING

Thread-up the Knot Sensor using Air-threading + Plastic Threading Needle.

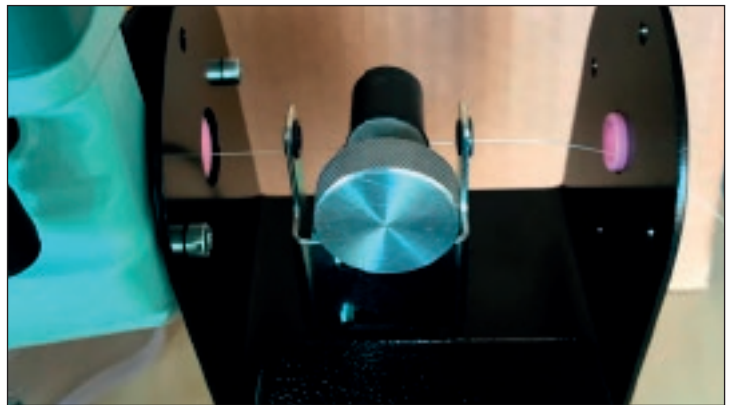

3. SETTING ADJUSTMENT

Turn the Adjustment Knob to adjust the gap between the roller and the sensor to trigger when a knot is detected.

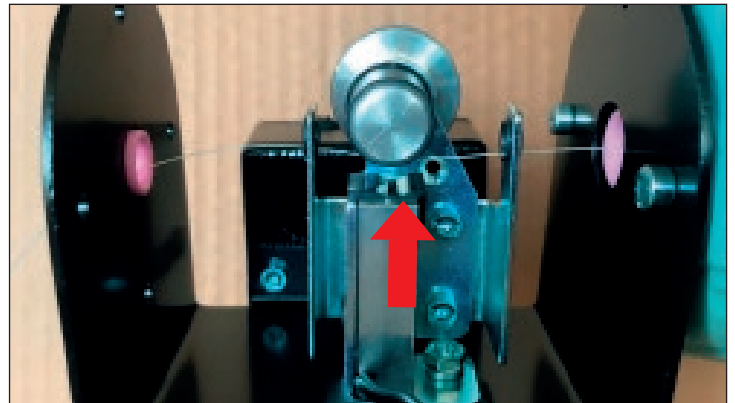
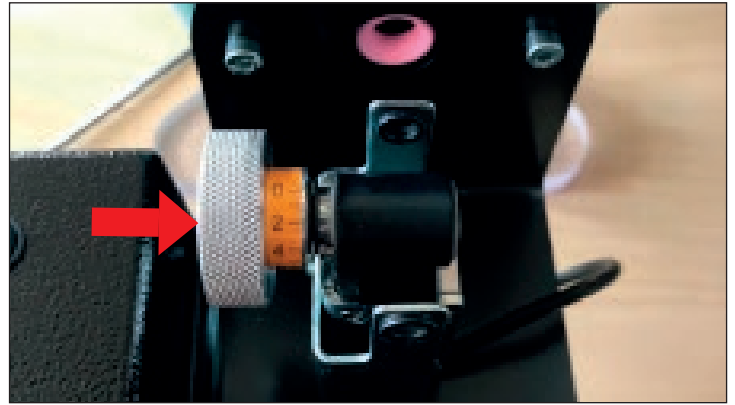



Bobbin Switch Sensor



Compact Sensor designed for integration in the CAN communication system. It is designed to give an instantaneous, reliable indication of bobbin switch-over, allowing the weaving machine to take the appropriate measures. The BSS is extremely simple to install.

Use with: All X2 and X3 weft feeders

1. USABILITY

Compact Sensor and designed to give an instantaneous, reliable indication of bobbin switch-over, allowing the weaving machine to take the appropriate measures. Easy to install with multiple uses.

Examples how the sensor works:

- Signal that yarn bobbin need renewing
- Activate knot removal cycle (between yarn bobbins) for knot free weaving
- Signal to change the air pressure on an Airjet machine

2. SETTING

Mount the sensor to the bobbin stand and connect the cable to the feeder, The Picanol versions are connected to the weaving machine.

Tie together the end yarn from the first bobbin to the start of the second one; thread the yarn into the sensor with the knot on the second bobbin side.

Part numbers:

40-0582-001 One long cable X3 feeders

40-0582-002 Picanol version rapier

40-0582-003 Two cables X3 feeders

40-0582-111 One long cable X2 feeders

40-0582-113 Two cables X2 feeder, clamp

40-0582-313 Two cables X2 feeders, mount

40-0582-900 Picanol Airjet

Spare parts:

For information regarding spare parts contact IRO Service or local Agent.

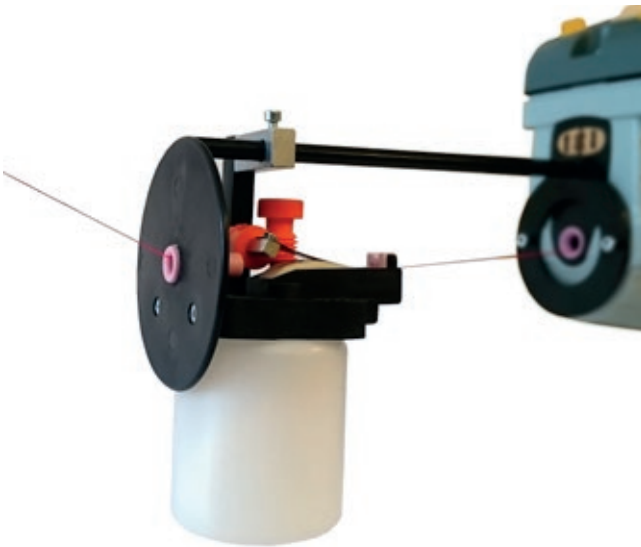

Mechanical Weft Lubricator



By using a mechanical weft lubricator the traditional dispensing method to apply oil (or other fluids) on to the weft yarn is possible to give increased yarn strength and improved performance.

The lubricator is available both as a “feeder-mounted” version, and as a “creel-mounted” version.

Use with: All type of weft feeders

1. USABILITY

The lubricator is available as a feeder mounted version and a creel mounted version.

The lubricator is especially suitable for yarns that are sensitive to variations in the amount of oil applied; the speed of the oiling wheel is fully synchronized with the feeder speed.

It is used to apply oil or other fluids on the weft yarn in order to increase the strength of the yarn/or reduce friction.

2. SETTING

Thread the lubricator through the eyelets and turn the knob on top so that the leaf presses the weft yarn down towards the wick in order to apply oil or other fluids to the yarn.

Part numbers:

40-0235	Oiler kit Feeder mount
40-0236	Oiler Bobbin stand

Spare parts:

40-0355	Wick
40-0354	Tension leaf
40-0356	Eyelet

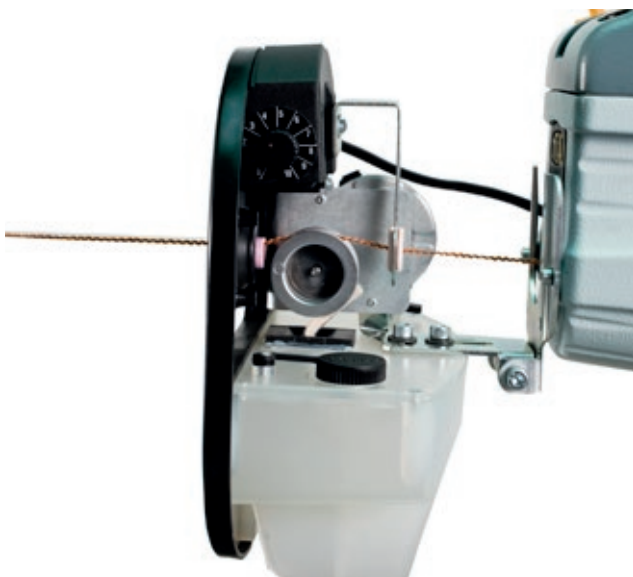

Powered Weft Lubricator



The powered weft lubricator is an automatically controlled oil dispensing device for use on all X2/X3 series feeders. The Oiler is integrated into the systems communications network and is therefore fully synchronized with the feeder's insertion speed.

Use with: All type of weft feeders

1. USABILITY

The lubricator can be used on all X2/X3 series of feeders.

The lubricator is especially suitable for yarns that are sensitive to variations in the amount of oil applied; the speed of the oiling wheel is fully synchronized with the feeder speed.

2. SETTING

Thread the lubricator through the eyelets and connect the power cable to the feeder.

The amount of oil is set with the adjustment knob, range from zero to ten.

Spare parts:

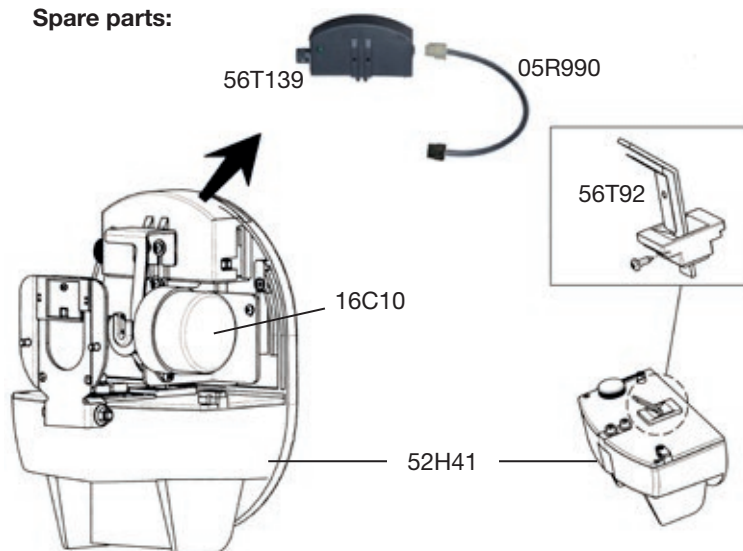

Part numbers:

56T00200



CARPET WEAVING MACHINES

VELVET WEAVING MACHINES

TUFTING SYSTEMS

ADVANCED KNITTING TECHNOLOGY

YARN EXTRUSION LINES

ADVANCED HEAT-SETTING SOLUTIONS

SHEDDING SYSTEMS

HARNESSES

WEFT INSERTION SYSTEMS

FINISHING MACHINES

YARN TRADING

QUALITY ASSURANCE FOR TEXTILES

PRODUCTION MANAGEMENT SOLUTIONS

MOTORS & DRIVES

HIGH PRECISION IRON FOUNDRY

BULK HANDLING

We imagine, build and integrate innovative textile systems for flooring qualities, home linen, fashion fabrics and technical textiles.

Sharing inspiration and expertise with our customers worldwide, we shape the textile industry of the future.

Creating success for them all, from yarn to finished product.

ROJ[®] ROJ Srl
Via Vercellone 11
IT-13900 BIELLA
ITALY
☎ +39 015 84 80 111
☎ +39 015 40 58 15
@ comm@roj.com
🌐 www.roj.com

iro[®] IRO AB
Box 54
SE-523 22 ULRICEHAMN
SWEDEN
☎ +46 321 297 00
☎ +46 321 298 00
@ info@iro.se
🌐 www.iroab.com