

ERGOBJÖRN 709



EASY TO HANDLE AND A JOY TO DRIVE

Developed for order picking. It is one of few trucks allowed to be driven on mezzanine floors. The compact design means a short turning radius.

ERGONOMIC CONTROLS

Ergonomy and smart functions make the truck intuitive and easy to drive. It is free from disturbing details.

GOOD OVERVIEW

The compact design provides a good overview in all directions, which increases safety.

FUNCTIONAL LED LIGHTS

Attractive design in combination with good function. Features that characterises a successful product.

WELL-THOUGHT OUT DRIVER SPACE

Wide, ergonomic and non-vibrating rubber floor. Works with presence control, where the truck can be driven only when the driver stands on the rubber platform. It also has smart compartments for storage.

UNIQUE DOCKING SOLUTION

Provides a closeness for efficient order picking. The solution also means high flexibility when it is easy to change between different types of trolleys.

EXTRA LOW IN-STEP – 70 MM

Probably the market's lowest in-step height contributes to a higher comfort.

STRONG ELECTRIC AC-DRIVE – INCREASED TOWING CAPACITY

Quieter, stronger and more sustainable. A 70% more powerful engine provides a prolonged running time.

EASY BATTERY EXCHANGE – 20 SECONDS

Easy handling of battery exchange which only takes 20 seconds. Requires no specific area for charging.

NO HYDRAULICS, NO LEAKAGE

The truck is a "clean machine". No leakage from oil or battery acid.

Dimensions and technical data

Art No	14 16 47 09
Max. speed	12 km/h
Max. towing capacity	1000 kg depending on speed.
Max. gradient	10%
Length	1580 mm
Width	750 mm
Height	1100 mm
Threshold height	70 mm
Ground clearance	35 mm
Axle distance	1165 mm
Engine	
Electrical system	24 V (AC)
Power output	1000 W
Engine type	AC, "In-wheel-drive"
Drive wheels	ø250 x 80 Polyurethane

Rear wheels	ø200 x 50 Elastic
Support wheels	ø80 x 35 Polyurethane

Batteries

Valve-regulated, maintenance-free gel batteries. No specific charging room equipment required for charging.

Voltage	Capacity	Battery weight	Total
24 V	76 Ah/C5	57,6 kg	240 kg
24 V	105 Ah/C5	75 kg	260 kg

Trolleys

Suitable for trolleys 600 mm wide.

Examples of accessories

Flashlight, accessory holder, memo board, extra battery cassette, battery exchange table, waste bin, computer holder, foldable ladder, towing adapter etc.

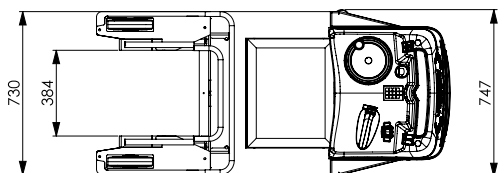
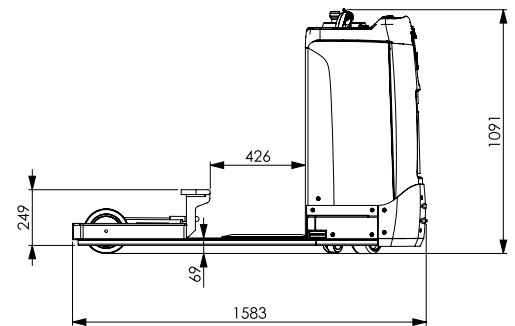

HelgeNyberg AB

HEAD OFFICE / SWEDEN

Industrivägen 2
SE-523 90 Ulricehamn

Phone +46 321 263 00
Fax +46 321 263 01

info@helge-nyberg.com
www.helge-nyberg.com

GERMANY

Mobile +49 160 99 143 743
Fax +46 321 263 01