

LOAD CARRIERS

SERIES 750

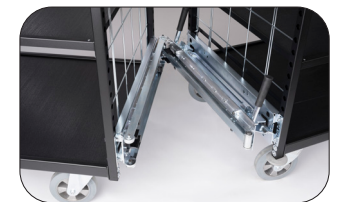

HelgeNyberg

HELGE NYBERG AB HAS THE SOLUTIONS TO YOUR NEEDS

Although all our customers have the same basic need for cost-effective, ergonomic material handling, their requirements may differ on crucial points and key details. Also, different industries often have different laws and regulations for products, certifications or other industry-specific requirements.

For this reason, we have specialised in a number of areas on the basis of over 60 years' collective experience and knowledge of our customers' needs. This allows us to offer the optimum solutions, the best service and the most secure collaboration.

A SPECIALIST PROVIDING SOLUTIONS FOR MANY SEGMENTS



INDUSTRY & MANUFACTURING

Helge Nyberg operates in both light and heavy industries. We have industrial solutions for the entire material flow.



E-COMMERCE & ORDER PICKING

With our long history and our location in a geographic area with many mail order, logistics and warehousing businesses, we have unique know-how and experience in order picking and third party logistics.



HEALTH & MEDICAL CARE

All industries have different requirements and specifications regarding materials and professional equipment. The strictly regulated health care sector has certain specific requirements. We can meet those requirements.



AUTOMOTIVE INDUSTRY

The automotive industry has seen perhaps the most advanced developments in smart logistics. Helge Nyberg's solutions are part of these developments.

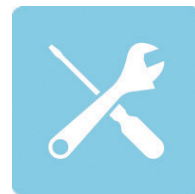

SERVICE & SUPPORT

Our truck and trolley solutions are not only ideal for transporting baggage or materials, for instance at airports and trade fairs. They are just as frequently used as wheeled service points by technicians and installers, for example in factories.



LEAN SOLUTIONS

As specialists, we can help you develop the most resource-efficient solutions to your material handling needs – the right material, in the right place at the right time.

SERIES 750

LOAD CAPACITY OF 750 KG



STRONGER IN EVERY WAY

Suitable for order picking in e-commerce and for long haul heavy goods transport. The load carriers in our 750 series are stronger in all respects, due to their build and design. Now you can load 750 kg onto each load carrier and use every millimetre of shelf space. The shelves are fixed with screws, making it simple to reconfigure the trolley as needed. Reinforced wheels and wheel brackets make towing easier. The wide range of trolley types and shelf sizes ensures flexibility and makes it easy to adapt the trolley to the job at hand.

ADAPTED TO YOUR NEEDS

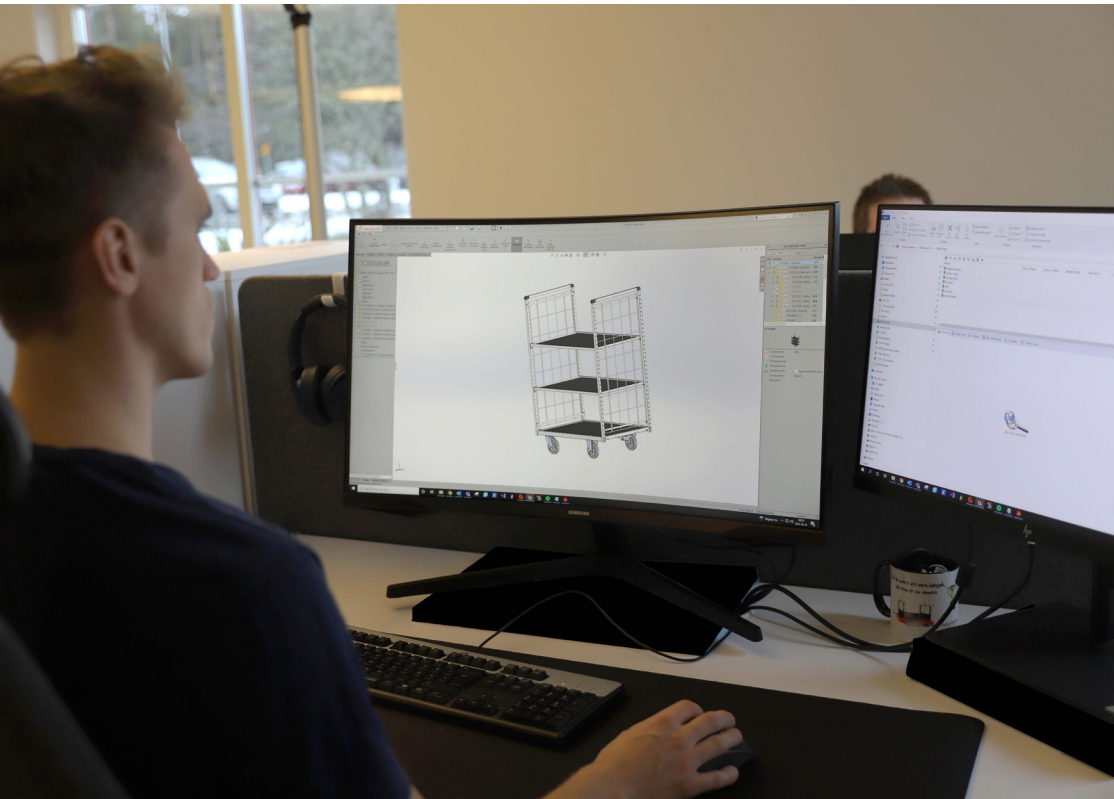

CUSTOMISED SOLUTIONS

For Helge Nyberg, it's not a problem to provide customised solutions. We see it as a challenge that develops our own as well as the user's daily work. Thanks to our R&D department's experience and solid know-how, we have gained a reputation for providing value-adding solutions tailored to customers' requirements.

Do you have specific requests for your company? We'll solve it in collaboration with you.



TROLLEYS FOR TOWING TRUCKS

All our trolleys in 750 series have a load capacity of 750 kg. With their excellent ergonomics and high quality, they help raise profitability in companies that handle goods in-house. The wide range of trolley types and shelf sizes ensures flexibility and makes it easy to adapt the trolley to the job at hand. The trolleys can be tailored to suit most needs with the help of smart accessories. The shelves have raised edges, grooved surfaces and end grids to keep the cargo firmly in place. The trolleys have a maximum speed of 12 km/h.

ADAPTED TO YOUR NEEDS

TROLLEYS FOR TOWING TRUCKS

Our shelf trolleys are designed for use with towing trucks to transport larger quantities of goods in narrow spaces. The trolleys' ends and shelves are reinforced to withstand loads up to 750 kg. The shelves are recessed in the frame profile and have a grooved surface to keep the products in place. The trolley is designed so that every millimetre of shelf space can be utilised. The trolleys in our 750 series are easy to reconfigure and adapt to the job at hand.

Max. load 750 kg. Lower shelf has a max. load of 750 kg. Upper shelves have a max. load of 200 kg. Two fixed wheels and two swivel wheels, all with grey elastic rubber tyres measuring 200x50 mm, ball bearing hubs.



Item no.
15752682

Quick coupling with rear tow bar

Item no.	Shelves	Shelf dim.	Length	Width	Height
15752682	3	1,250x600	1,340	670	1,990
15752882	3	1,250x800	1,340	870	1,990
15754682	3	1,450x600	1,540	670	1,990
15754882	3	1,450x800	1,540	870	1,990
15756682	3	1,650x600	1,740	670	1,990
15756882	3	1,650x800	1,740	870	1,990

Quick coupling with front tow bar

Item no.	Shelves	Shelf dim.	Length	Width	Height
15752681	3	1,250x600	1,340	670	1,990
15752881	3	1,250x800	1,340	870	1,990
15754681	3	1,450x600	1,540	670	1,990
15754881	3	1,450x800	1,540	870	1,990
15756681	3	1,650x600	1,740	670	1,990
15756881	3	1,650x800	1,740	870	1,990

Tow bar coupling with front tow bar

Item no.	Shelves	Shelf dim.	Length	Width	Height
15752683	3	1,250x600	1,409	670	1,990
15752883	3	1,250x800	1,409	870	1,990
15754683	3	1,450x600	1,609	670	1,990
15754883	3	1,450x800	1,609	870	1,990
15756683	3	1,650x600	1,809	670	1,990
15756883	3	1,650x800	1,809	870	1,990

Tow bar coupling with rear tow bar

Item no.	Shelves	Shelf dim.	Length	Width	Height
15752680	3	1,250x600	1,409	670	1,990
15752880	3	1,250x800	1,409	870	1,990
15754680	3	1,450x600	1,609	670	1,990
15754880	3	1,450x800	1,609	870	1,990
15756680	3	1,650x600	1,809	670	1,990
15756880	3	1,650x800	1,809	870	1,990



Item no.
15752683

QUICK

With the Quick towing device, the tow bar is fitted facing forwards or backwards and connects from underneath. The device is easy to release with a simple foot movement, making Quick one of our most ergonomic towing devices.



ACCESSORIES – TROLLEYS FOR TOWING TRUCKS



EXTRA SHELVES

Item no.	Shelf dim.
12752526	1,250x600
12752528	1,250x800
12752546	1,450x600
12752548	1,450x800
12752566	1,650x600
12752568	1,650x800

Extra shelf in a choice of three lengths. It is easy to assemble and adjust the height of the shelves. The shelves have a grooved surface and a raised edge.



SHELF DIVIDER

Item no.	Width
10750004	600
10750007	800
Compatible with chassis 10750009	600
10750010	800

Easy to reposition or remove. Available for all truck sizes.

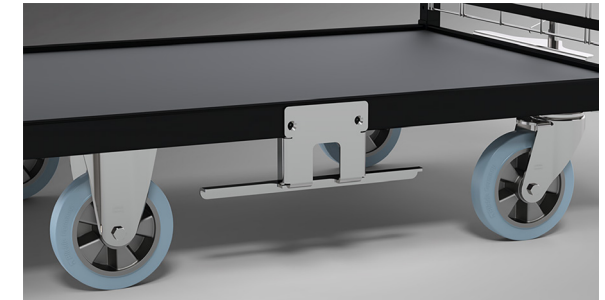

TRUCK FORK GUIDE

Item no.	Width
12750011	600
12750011	800

For handling trolleys from the side. Please specify distance between the truck forks and the forks' height at the highest point when ordering.

EFFICIENCY



SUSTAINABILITY

LOGISTICS & ERGONOMICS

An integrated truck and trailer system and trolleys with adjustable shelves are examples of solutions that improve worker ergonomics. These solutions also make order picking more efficient. Quite simply, the right equipment makes the job faster. Our trucks can easily be adapted both to the job at hand and to individual physical requirements. This makes employees' work easier and improves their physical and mental health.

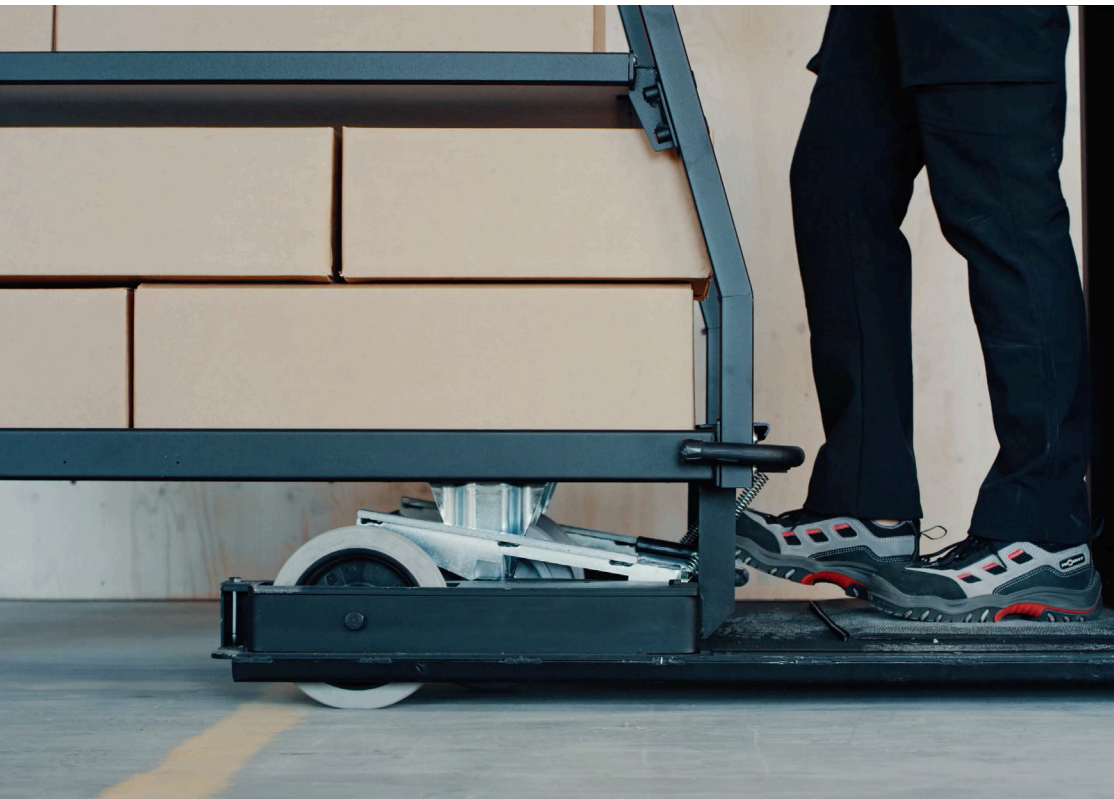

ERGONOMICS

KEEP YOUR STAFF HEALTHY AND YOUR COSTS DOWN



1. PRIORITY TO ERGONOMICS

Ergonomic solutions – such as trucks with a low entry threshold and a non-vibrating platform, or trailers with a ladder and adjustable shelves and handles – offer economic benefits by reducing the costs of sick leave and rehabilitation.

2. TIME IS MONEY

Walk less, save costs. Our trains of trolleys with a pick-train connection reduce the walking distance when picking orders. This improves cost-effectiveness by saving time. Here are more examples of how to rationalise your order picking to save time and money.

3. SMART PICKING SOLUTIONS

Do you have a growing company? Review your warehouse logistics. When your business grows and material handling increases, you don't necessarily need to expand your warehouse. Helge Nyberg has smart, modern, cost-effective picking and transport solutions that can be tailored to suit your warehouse. Efficiency is key in keeping staff costs down. We help you rationalise your warehouse logistics.

TROLLEYS FOR PICKING TRUCKS

All our trolleys in 750 series have a load capacity of 750 kg. With their good ergonomics and high quality, they help raise profitability in companies where light goods are handled in-house. The wide range of trolley types and shelf sizes ensures flexibility and makes it easy to adapt the trolley to the job at hand. The trolleys can be tailored to suit most needs with the help of smart accessories. The shelves have raised edges, grooved surfaces and end grids to keep the cargo firmly in place. The trolleys have a maximum speed of 12 km/h.



STEP TROLLEY

Trolley with steps for picking and replenishment in warehouse and production facilities. The combined solution provides an efficient mobile workplace, e.g. for order picking up to a height of 3 metres. The uprights are held together by a top element. All shelves are recessed in the frame profile. Fixed distance between shelves, 512 mm for 3-shelf trolley. The 4-shelf trolley has a distance of 362 mm between the bottom shelf and first shelf and 318 mm between the other shelves. Max. load 750 kg. Max. load, shelves 200 kg. Max. load, product resting shelf 40 kg. Two fixed docking wheels with tugs and two swivel wheels, all with grey elastic rubber tyres measuring 200x50 mm, ball bearing hubs. Shelf divider available as optional accessory.

3 shelves

Item no.	Shelves	Bottom shelf	Middle shelf	Top shelf	Length	Width	Height
15752695	3	1,250x600	1,120x600	955x600	1,373	707	2,280

4 shelves

Item no.	Shelves	Bottom shelf	Middle shelf 1	Middle shelf 2	Top shelf	Length	Width	Height
15752696	4	1,250x600	1,156x600	1,055x600	955x600	1,373	707	2,280



REDUCE YOUR PICKING TIME

These shelf trolleys are designed for use with picking trucks. The trolleys' ends and shelves are reinforced to withstand loads up to 750 kg. The shelves are recessed in the frame profile and have a grooved surface to keep the products in place. The trolley is designed so that every millimetre of shelf space can be used. It is light and handy for order picking. The docking system makes it quick and easy to change the trolleys. The trolleys in our 750 series are easy to reconfigure and adapt to the job at hand.

Max. load 750 kg. Lower shelf has a max. load of 750 kg. Upper shelves have a max. load of 200 kg. Two fixed docking wheels with tugs and two swivel wheels, all with grey elastic rubber tyres measuring 200x50 mm, ball bearing hubs.



Item no.
15752685

Docking trolley (A-trolley)

Item no.	Shelves	Shelf dim.	Length	Width	Height
15752690	3	1,250x600	1,361	707	1,990
15754690	3	1,450x600	1,561	707	1,990
15756690	3	1,650x600	1,761	707	1,990

TROLLEYS FOR PICKING TRUCKS 709



Item no.
15752690

Ready-prepared for pick-train connection (B-trolley)

Item no.	Shelves	Shelf dim.	Length	Width	Height
15752685	3	1,250x600	1,340	670	1,990
15754685	3	1,450x600	1,540	670	1,990
15756685	3	1,650x600	1,740	670	1,990

ACCESSORIES – TROLLEYS FOR PICKING TRUCKS 709

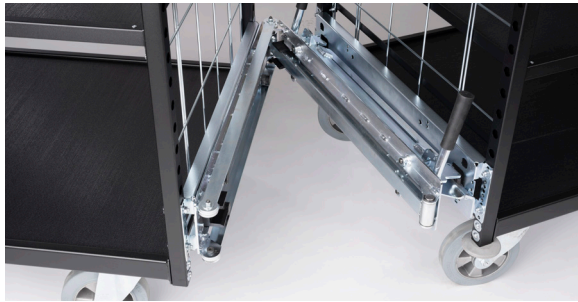

PICK-TRAIN

Item no.	Width
12753406	600

This solution has ergonomic benefits and also shortens picking times by reducing the picker's walking distance. Up to two trolleys can be used in the train.



EXTRA SHELVES

Item no.	Shelf dim.
12752526	1,250x600
12752546	1,450x600
12752566	1,650x600

Extra shelf in a choice of three lengths. It is easy to assemble and adjust the height of the shelves. The shelves have a grooved surface and a raised edge.



SHELF DIVIDER

Item no.	Width
10750004	600
Compatible with chassis 10750009	600

Easy to reposition or remove. Available for all truck sizes and models.

PICK-TRAIN



Pick-train is designed to shorten the distance between the trolleys in a train. This solution has ergonomic benefits and also shortens picking times by reducing the picker's walking distance. Up to two trolleys can be used in the train.

Pick-train can only be used with trolleys from Helge Nyberg AB and in combination with Helge Nyberg trucks. When pick-train is used in a train of trolleys, the second trolley in the train must not be dockable.



**SHORTER
PICKING TIMES**

STEP TROLLEY

Trolley with steps for picking and replenishment in warehouse and production facilities. The combined solution provides an efficient mobile workplace, e.g. for order picking up to a height of 3 metres. The uprights are held together by a top element. All shelves are recessed in the frame profile. Fixed distance between shelves, 512 mm for 3-shelf trolley. The 4-shelf trolley has a distance of 362 mm between the bottom shelf and first shelf and 318 mm between the other shelves. Max. load 750 kg. Max. load, shelves 200 kg. Max. load, product resting shelf 40 kg. Two fixed docking wheels with tugs and two swivel wheels, all with grey elastic rubber tyres measuring 200x50 mm, ball bearing hubs. Shelf divider available as optional accessory.

3 shelves

Item no.	Shelves	Bottom shelf	Middle shelf	Top shelf	Length	Width	Height
15752895	3	1,250x800	1,113x800	955x800	1,373	907	2,280

4 shelves

Item no.	Shelves	Bottom shelf	Middle shelf 1	Middle shelf 2	Top shelf	Length	Width	Height
15752896	4	1,250x800	1,156x800	1,055x800	955x800	1,373	907	2,280



EASY TO DRIVE IN NARROW SPACES

These shelf trolleys are designed for use with picking trucks. The trolleys' ends and shelves are reinforced to withstand loads up to 750 kg. The shelves are recessed in the frame profile and have a grooved surface to keep the products in place. The trolley is designed so that every millimetre of shelf space can be used. It is light and handy for order picking. The docking system makes it quick and easy to change the trolleys. The trolleys in our 750 series are easy to reconfigure and adapt to the job at hand.

Max. load 750 kg. Lower shelf has a max. load of 750 kg. Upper shelves have a max. load of 200 kg. Two fixed docking wheels with tugs and two swivel wheels, all with grey elastic rubber tyres measuring 200x50 mm, ball bearing hubs.



Item no.
15752890

TROLLEYS FOR PICKING TRUCKS 710

Docking trolley (A-trolley)

Item no.	Shelves	Shelf dim.	Length	Width	Height
15752890	3	1,250x800	1,361	907	1,990
15754890	3	1,450x800	1,561	907	1,990
15756890	3	1,650x800	1,761	907	1,990

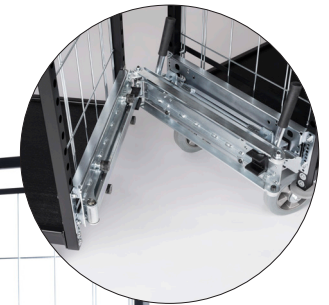

Item no.
15752885

Ready-prepared for pick-train connection (B-trolley)

Item no.	Shelves	Shelf dim.	Length	Width	Height
15752885	3	1,250x800	1,340	870	1,990
15754885	3	1,450x800	1,540	870	1,990
15756885	3	1,650x800	1,740	870	1,990

ACCESSORIES – TROLLEYS FOR PICKING TRUCKS 710



EXTRA SHELVES

Item no.	Shelf dim.
12752528	1,250x800
12752548	1,450x800
12752568	1,650x800

Extra shelf in a choice of three lengths. It is easy to assemble and adjust the height of the shelves. The shelves have a grooved surface and a raised edge.



SHELF DIVIDER

Item no.	Width
10750007	800
Compatible with chassis 10750010	800

Easy to reposition or remove. Available for all truck sizes.

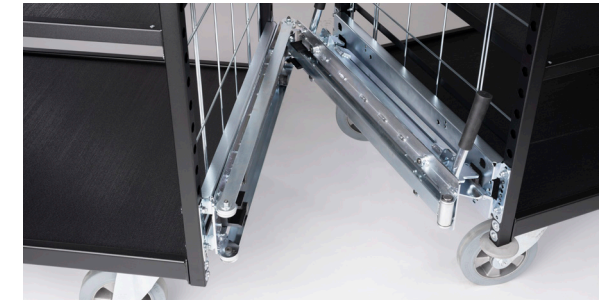

PICK-TRAIN

Item no.	Width
12753408	800

This solution has ergonomic benefits and also shortens picking times by reducing the picker's walking distance. Up to two trolleys can be used in the train.



TURN RADIUS – PICK-TRAIN

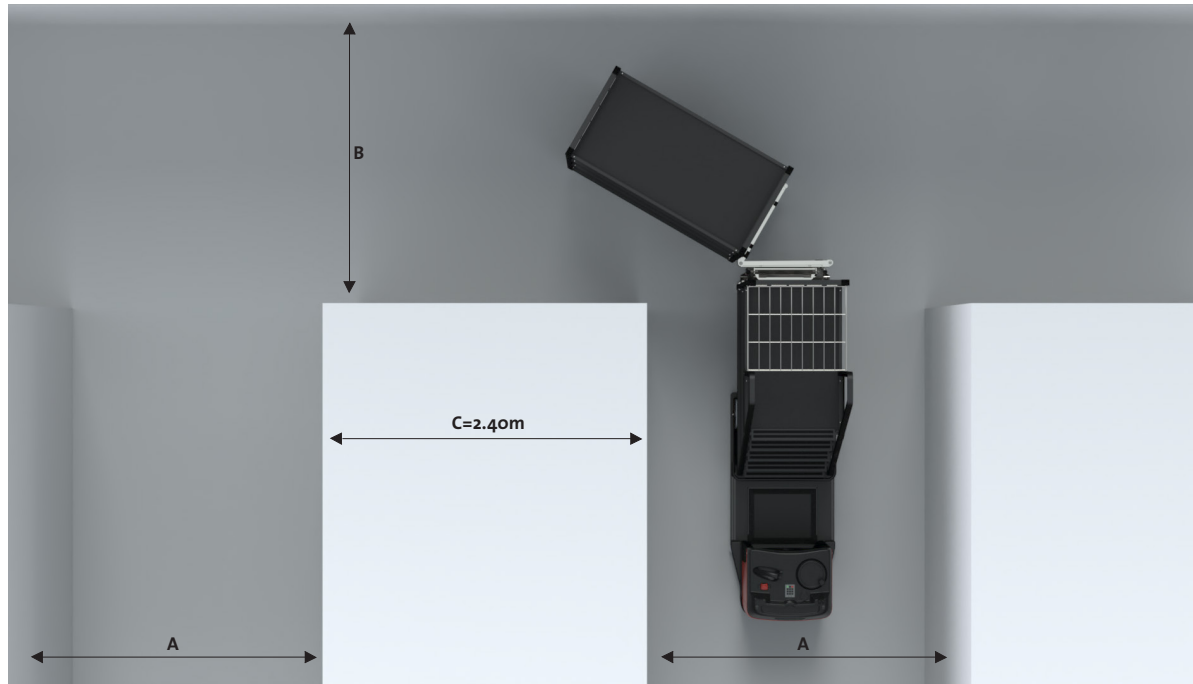

Number of trolleys	Trolley model	Shelf dim.	A-aisle (mm)	B-aisle (mm)	U-turn (mm)
1	15 75 28 85	1,250x800	2,000	1,500	2,800
2	15 75 28 85	1,250x800	2,000	1,500	3,750
1	15 75 48 85	1,450x800	2,000	1,750	3,000
2	15 75 48 85	1,450x800	2,000	2,000	4,250
1	15 75 68 85	1,650x800	2,000	2,000	3,200
2	15 75 68 85	1,650x800	2,000	2,500	4,500

TURN RADIUS – QUICK

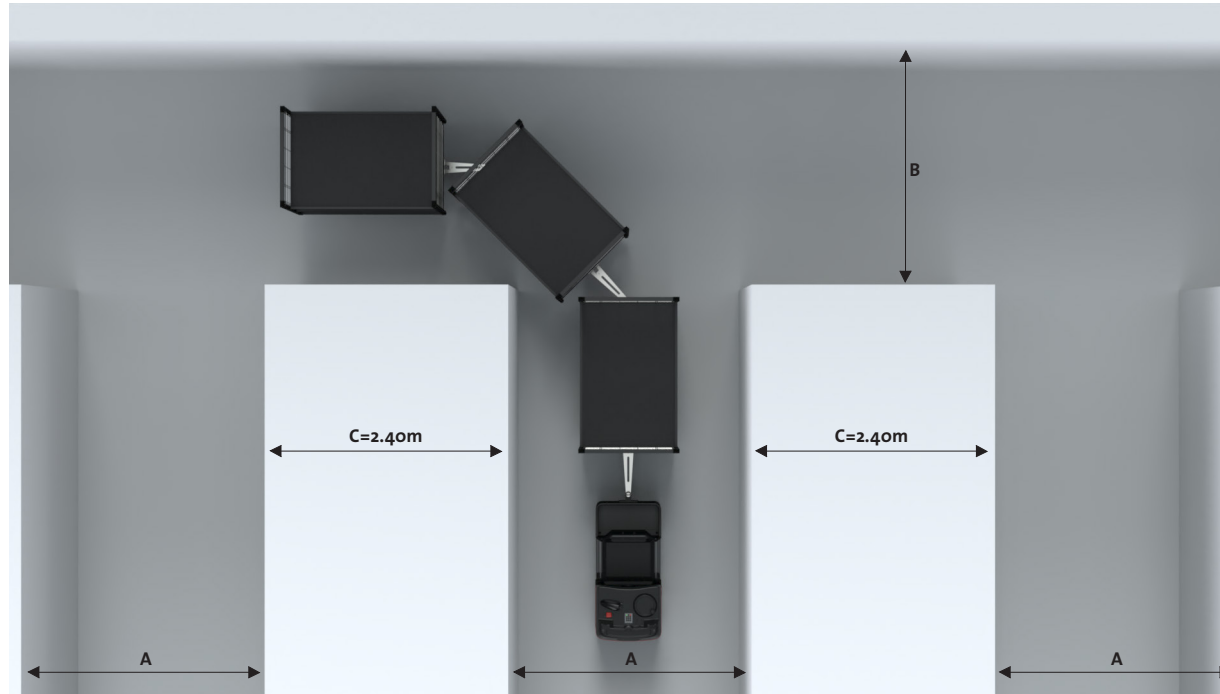

Number of trolleys	Trolley model	Shelf dim.	A-aisle (mm)	B-aisle (mm)	U-turn (mm)
1	15 75 28 81	1,250x800	2,000	1,500	2,700
2	15 75 28 81	1,250x800	2,000	2,000	3,600
3	15 75 28 81	1,250x800	2,000	3,000	4,000
1	15 75 48 81	1,450x800	2,000	2,000	2,850
2	15 75 48 81	1,450x800	2,000	2,500	4,000
3	15 75 48 81	1,450x800	2,000	3,500	4,350
1	15 75 68 81	1,650x800	2,000	2,000	3,000
2	15 75 68 81	1,650x800	2,000	3,000	4,500
3	15 75 68 81	1,650x800	2,000	4,000	4,700

Number of trolleys	Trolley model	Shelf dim.	A-aisle (mm)	B-aisle (mm)	U-turn (mm)
1	15 75 28 82	1,250x800	2,000	1,500	3,000
2	15 75 28 82	1,250x800	2,000	2,000	3,600
3	15 75 28 82	1,250x800	2,000	2,000	4,000
1	15 75 48 82	1,450x800	2,000	1,500	3,250
2	15 75 48 82	1,450x800	2,000	2,000	3,800
3	15 75 48 82	1,450x800	2,000	3,000	4,250
1	15 75 68 82	1,650x800	2,000	1,500	3,500
2	15 75 68 82	1,650x800	2,000	2,000	4,500
3	15 75 68 82	1,650x800	2,000	3,500	5,000

TURN RADIUS – TOW BAR

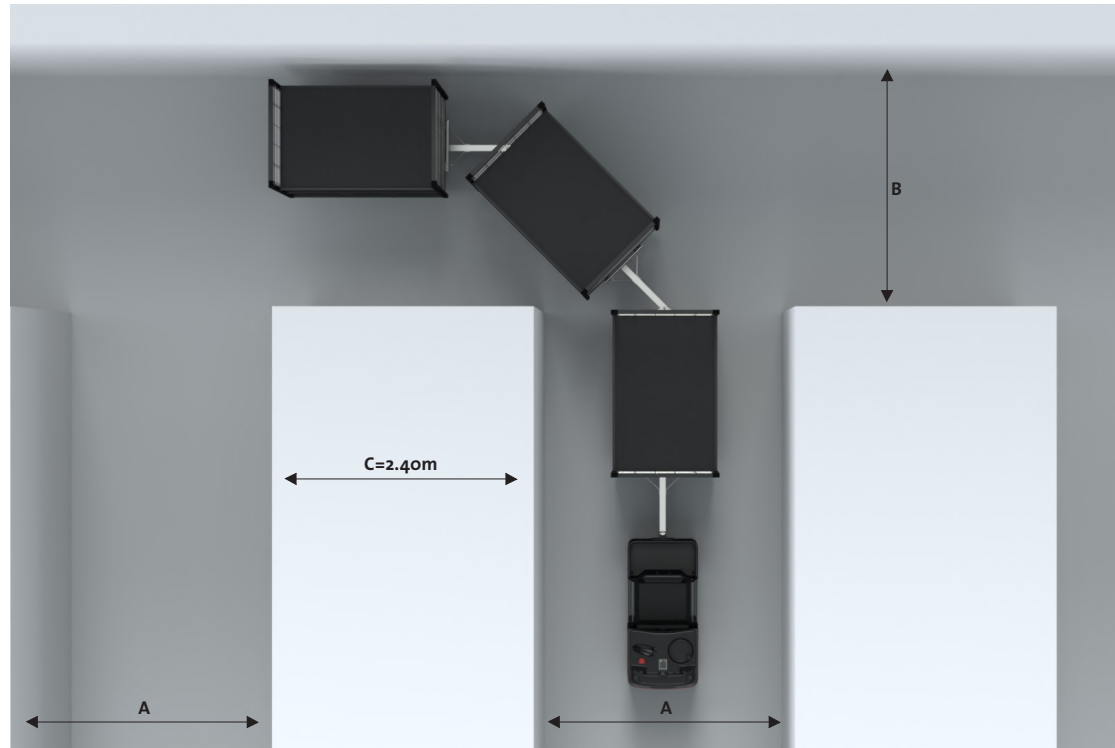

Number of trolleys	Trolley model	Shelf dim.	A-aisle (mm)	B-aisle (mm)	U-turn (mm)
1	15 75 28 83	1,250x800	2,000	1,500	2,700
2	15 75 28 83	1,250x800	2,000	2,000	3,600
3	15 75 28 83	1,250x800	2,000	3,000	4,000
1	15 75 48 83	1,450x800	2,000	2,000	2,850
2	15 75 48 83	1,450x800	2,000	3,500	4,000
3	15 75 48 83	1,450x800	2,000	3,500	4,350
1	15 75 68 83	1,650x800	2,000	2,000	3,000
2	15 75 68 83	1,650x800	2,000	3,000	4,500
3	15 75 68 83	1,650x800	2,000	4,000	4,700

Number of trolleys	Trolley model	Shelf dim.	A-aisle (mm)	B-aisle (mm)	U-turn (mm)
1	15 75 28 80	1,250x800	2,000	1,500	3,000
2	15 75 28 80	1,250x800	2,000	2,000	3,600
3	15 75 28 80	1,250x800	2,000	2,000	4,000
1	15 75 48 80	1,450x800	2,000	1,500	3,250
2	15 75 48 80	1,450x800	2,000	2,000	3,800
3	15 75 48 80	1,450x800	2,000	3,000	4,250
1	15 75 68 80	1,650x800	2,000	1,500	3,500
2	15 75 68 80	1,650x800	2,000	2,000	4,500
3	15 75 68 80	1,650x800	2,000	3,500	5,000



SINCE 1958 Helge Nyberg AB has been developing and manufacturing trolleys and lightweight electric trucks under the name of Ergobjörn for in-house material handling. As specialists, we raise the efficiency and cost-effectiveness of warehousing and logistics in sectors such as industrial manufacturing, health care, airports and e-commerce.

HelgeNyberg

HELGE NYBERG AB

Industrivägen 2
523 90 Ulricehamn, Sweden

Tel. +46 321 263 00
Fax +46 321 263 01

info@helge-nyberg.com
www.helge-nyberg.com